

Status Update

Daisy Kalra

Simons Team Meeting, March 13, 2026



Muon Ionization Cooling

- Muon ionization cooling channel –
 - HFOfO snake for initial 6D cooling of muons.
 - Reproduced many plots originally documented [here](#) from Yuri.
 - **Immediate goal** is to reproduce the remaining plots from Yuri and understand key parameters of the HFOfO channel (beam parameters, RF cavities).
 - **Long term goal** is to build a framework that integrates **initial 6D cooling with later final cooling stages**.

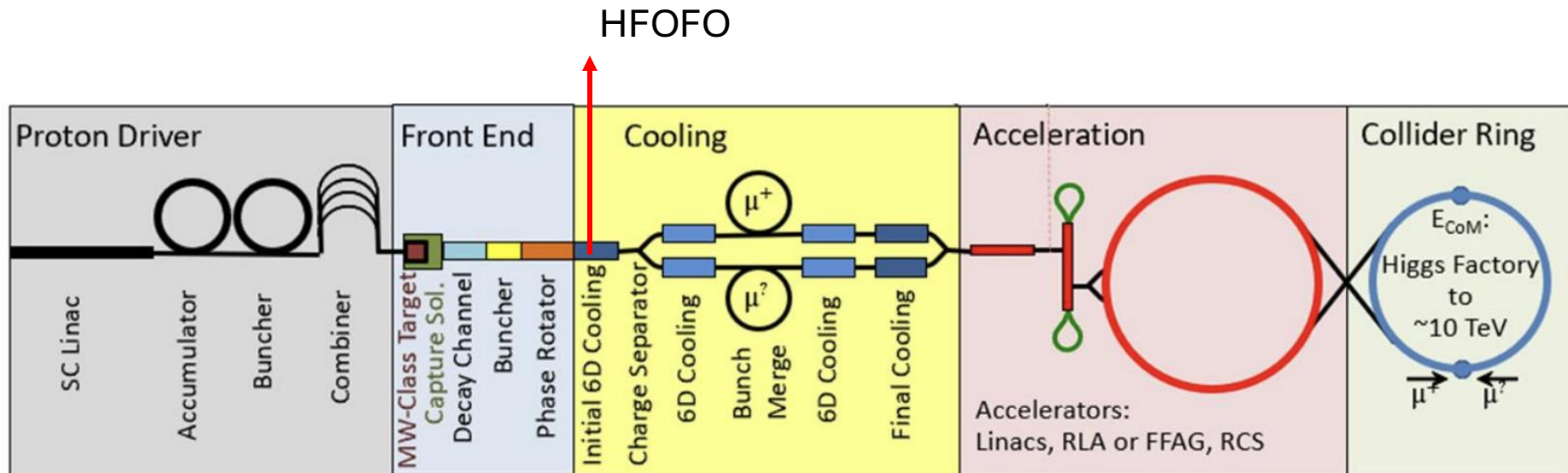

Muon Ionization Cooling

- Current status:

- Focusing on how RF timing (including offsets) affects the beam behavior in the cooling channel. (Daisy)
- Understanding how beamtime and timing offsets are set in the simulation. (Daisy)
- Optimizing these parameters to study their effect on beam momentum and RF phase evolution. (Daisy)
- Exploring ML algorithms for matching section (Rithika)
- Studying RF timing offsets in matching section (Rithika)

```
param beamtime=-0.671
param toffs0=$beamtime-$beamstart/275.79 -0.07

param toffs1=$toffs0-.061-.0026+.0115+.006 # ti
param toffs2=$toffs1-.064+.149-.0052-.0029
param toffs3=$toffs2
param toffs4=$toffs3
param toffs5=$toffs4-.008
param toffs6=$toffs5
```

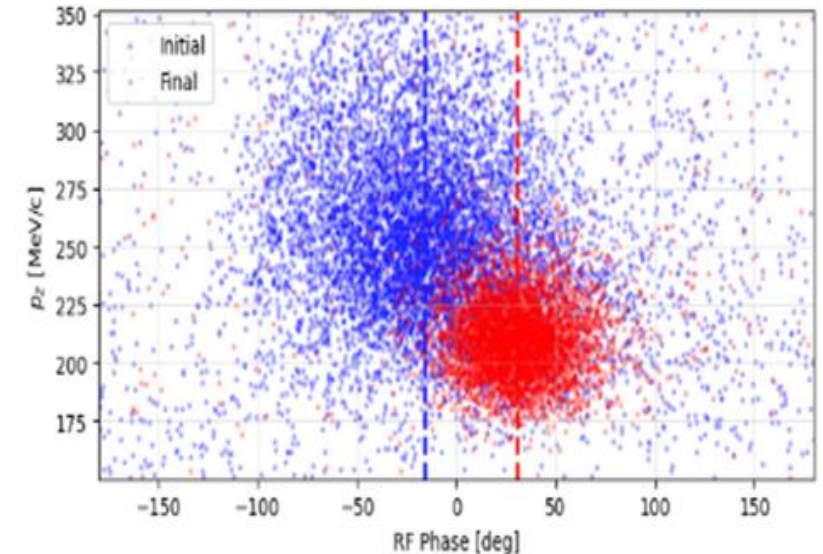

Particles at the **beginning** and **end** of HFOFO cooling channel

Ideally, the mean phase should stay same as the particles travel along the channel

Muon Ionization Cooling

- Areas of contribution:
 - Charge separator – HFOFO design is charge agnostic so the integration of initial and final cooling stages require charge separator.
 - ...

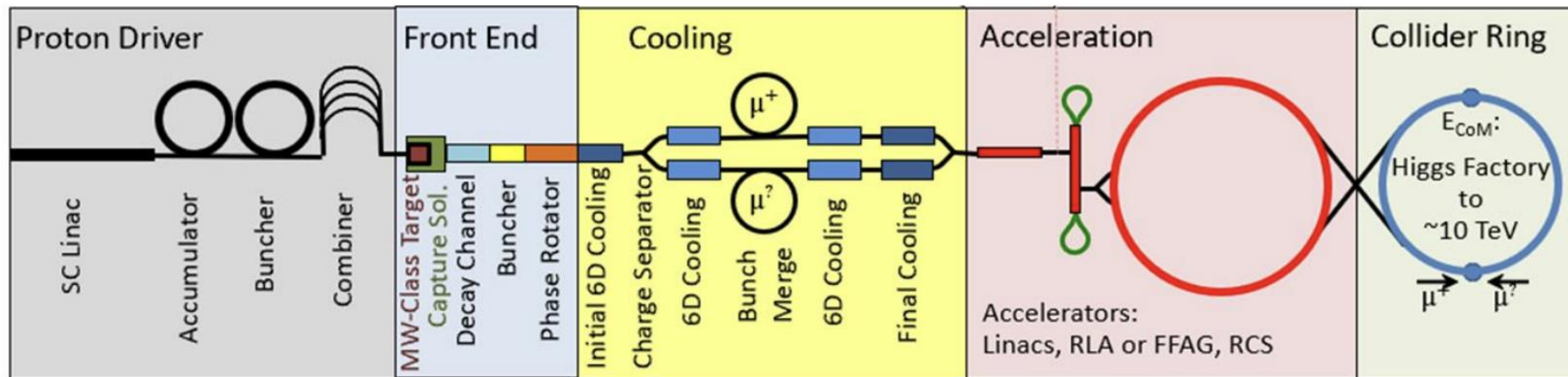

Neutrino Mitigation

- Immediate goal is to study neutrino interactions in the MAIA detector specifically in context of [Neutrino Slice](#) so as to explore ways to reduce them

Muon colliders provide an exciting new direction to expand the energy frontier of particle physics. We point out a new use of these facilities for neutrino and beyond the Standard Model physics *using their main detectors*. Muon decays along the accelerator rings create an intense and highly collimated neutrino beam that crosses a thin slice of the kt-scale detector. As a result, it would induce an unprecedented number of neutrino interactions, with $\mathcal{O}(10^4)$ events per second for a 10 TeV $\mu^+\mu^-$ collider. These interactions are highly energetic and possess a distinct timing signature and a large transverse displacement. We discuss promising applications of these events for instrumentation, electroweak, and beyond-the-Standard Model physics. For instance, a sub-percent measurement of the neutrino-electron scattering rate enables new precision measurements of the Weak angle and a novel detection of the neutrino charge radius.

Neutrino Mitigation

- Current status (Daisy):

- A generic GEANT model has been developed and validated by simulating electrons, protons, and muons.
- Neutrino physics has been implemented and is partially working; debugging and further validation checks are currently in progress.

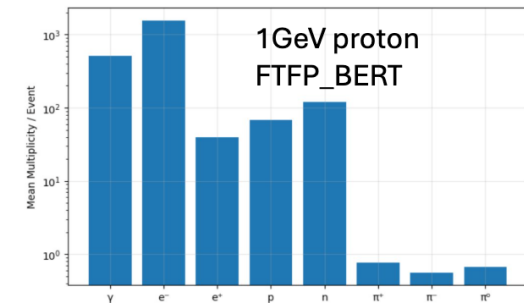
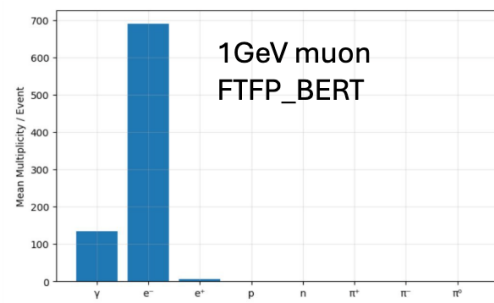
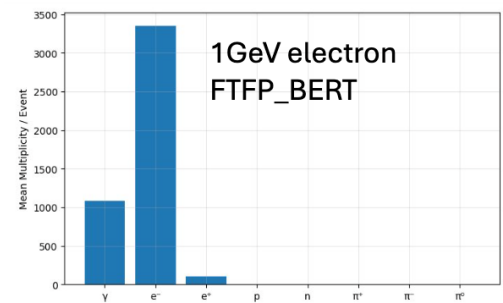

- Neutrino physics implementation is partially working

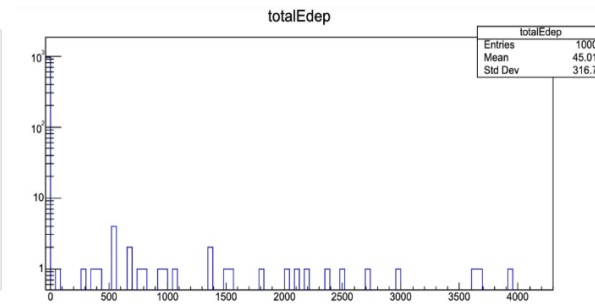
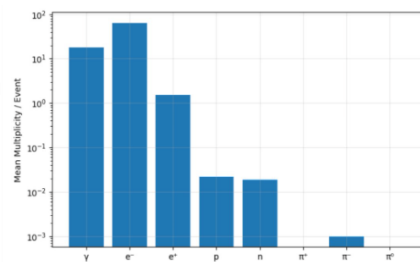

Neutrino Mitigation

- Areas of contribution:
 - Perform validation checks of neutrino physics through GEANT4 simulations.
 - Extending the program to include more information on primary and secondary particles.
 - Integrate and analyze neutrino slice information in the model.
 -

✓ <input type="checkbox"/> ROOT Files	
✓ <input type="checkbox"/> electron.root	nProtonSec
✓ tree;1	nSecondaries
E	nSteps
costh	phi
finalE	px
finalX	py
finalY	pz
finalZ	secFirstZ
nBackward	secLastZ
nCompton	secMeanE
nElectron	secTotalE
nGamma	secTrackLength
nIonisation	theta
nNeutron	totalEdep
nPairProd	x
nPionMinus	y
nPionPlus	z
nPionZero	
nPositron	