

Status Update

Daisy Kalra

Simons Team Meeting, March 27, 2026



Muon Ionization Cooling – HFOFO

- Optimizing RF phase in G4beamline for the HFOFO lattice using field map (Daisy)
 - Extract the actual RF phase from electric field values in and around RF cavities.
 - Compare it to particle RF phase (from its arrival time in the cavity) and reinterpret the phase.
- Optimizing matching and cooling section (Rithika)
 - Studying energy and momentum response with and without stochastics and absorbers.
 - Exploring ML algorithms for matching section.

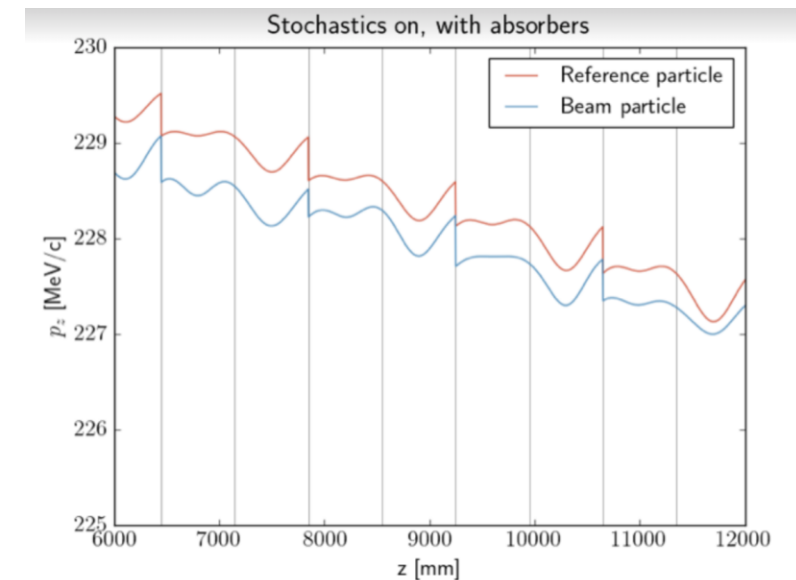
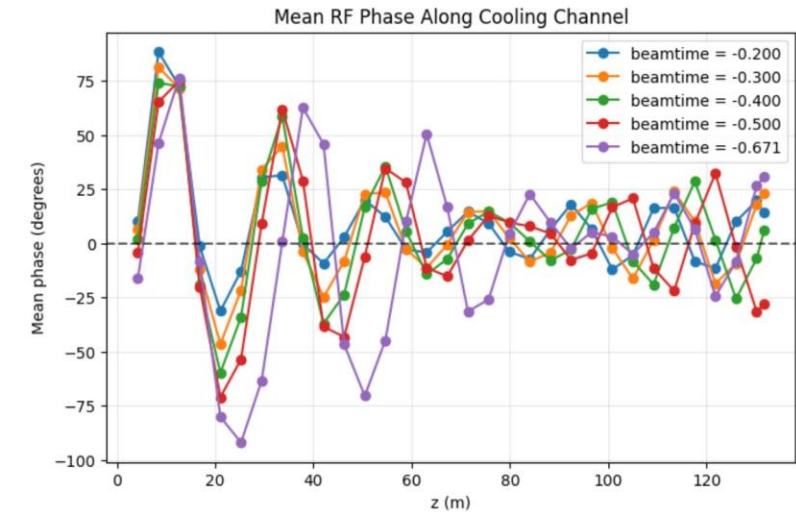

Muon Ionization Cooling

- Areas of contribution:
 - Currently, only the UTK group is working on HFOFO optimization projects; however, additional opportunities within HFOFO can be identified.
 - Charge separator – HFOFO design is charge agnostic so the integration of initial and final cooling stages require charge separator.

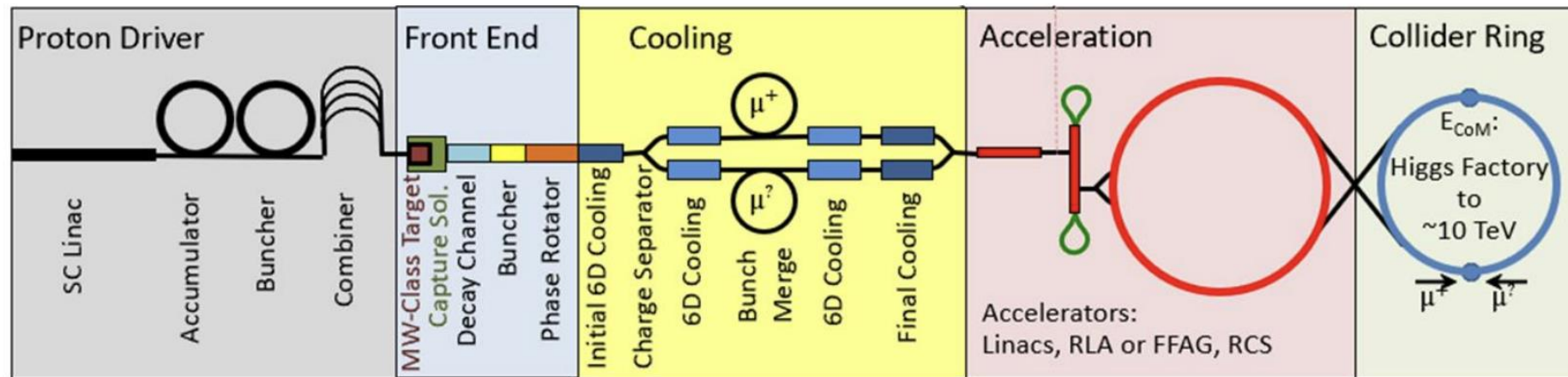

Neutrino Mitigation – Developing GEANT4 model

- Current status (Daisy):
 - Neutrino physics is implemented and well validated within GEANT4. An example validation is shown; additional checks were performed for both primary and secondary particles.

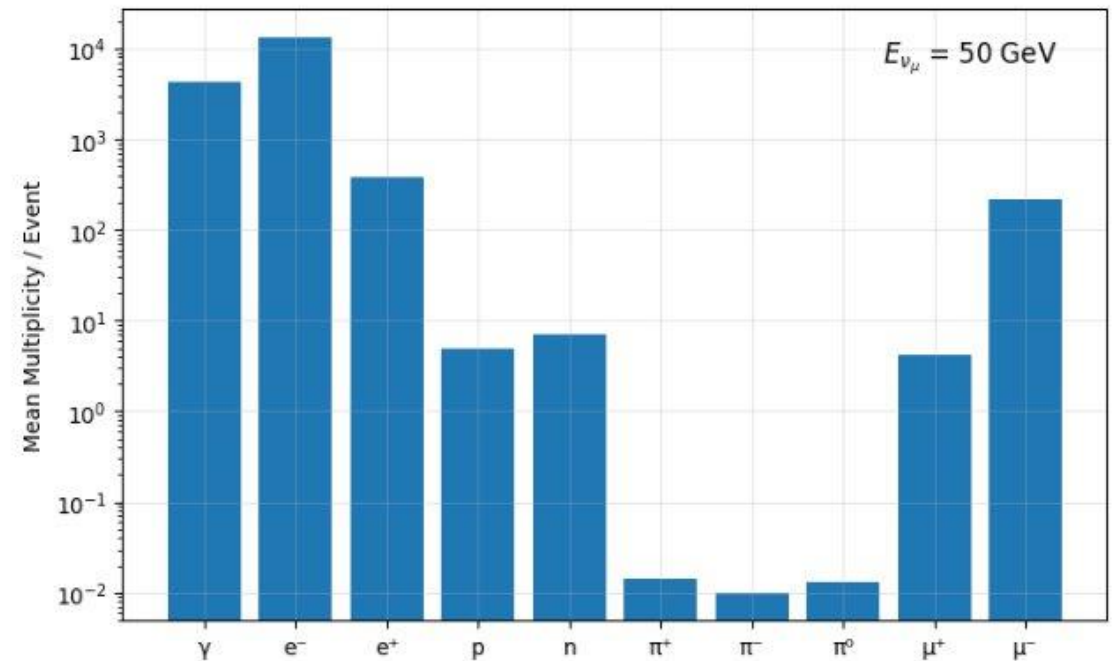
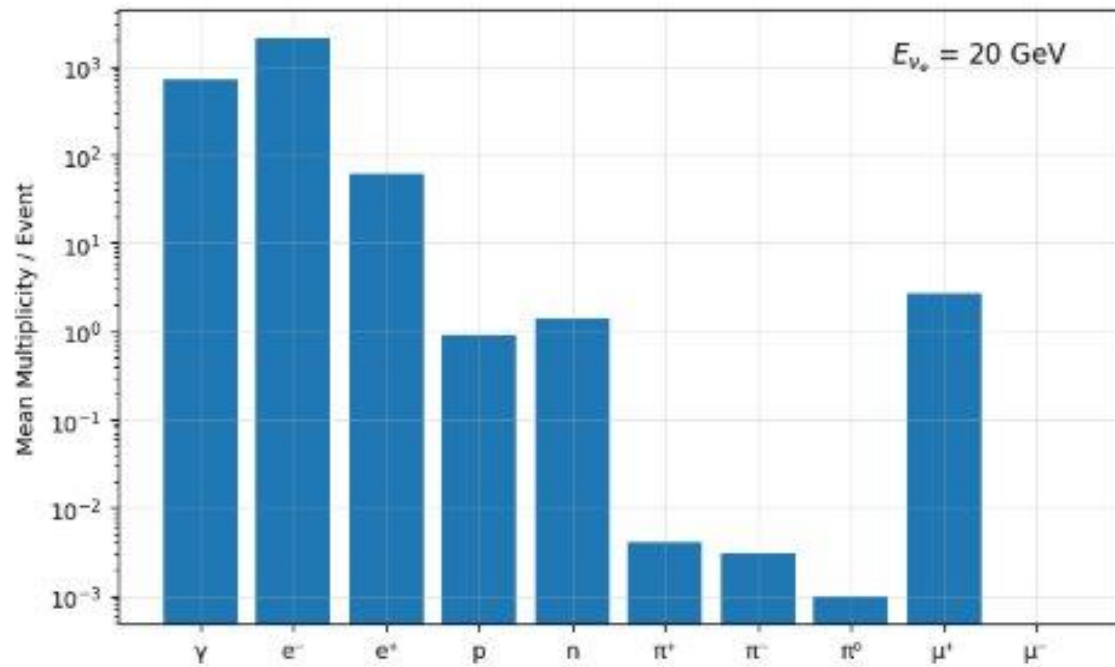

Neutrino Mitigation

- Areas of contribution:
 - Extending the program to include more information on primary and secondary particles.
 - Exploring GENIE for neutrino interactions.
 - Integrate and analyze neutrino slice information in the model.