

Status Update

Daisy Kalra

Simons Team Meeting, April 10, 2026



Muon Ionization Cooling – HFOFO

- Optimizing RF phase in G4beamline for the HFOFO lattice using field map (Daisy)
- Optimizing matching and cooling section by studying energy and momentum response (Rithika)

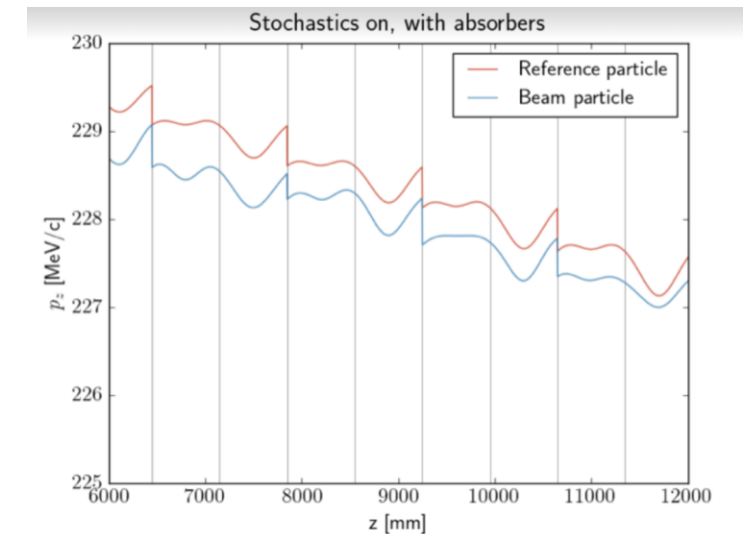
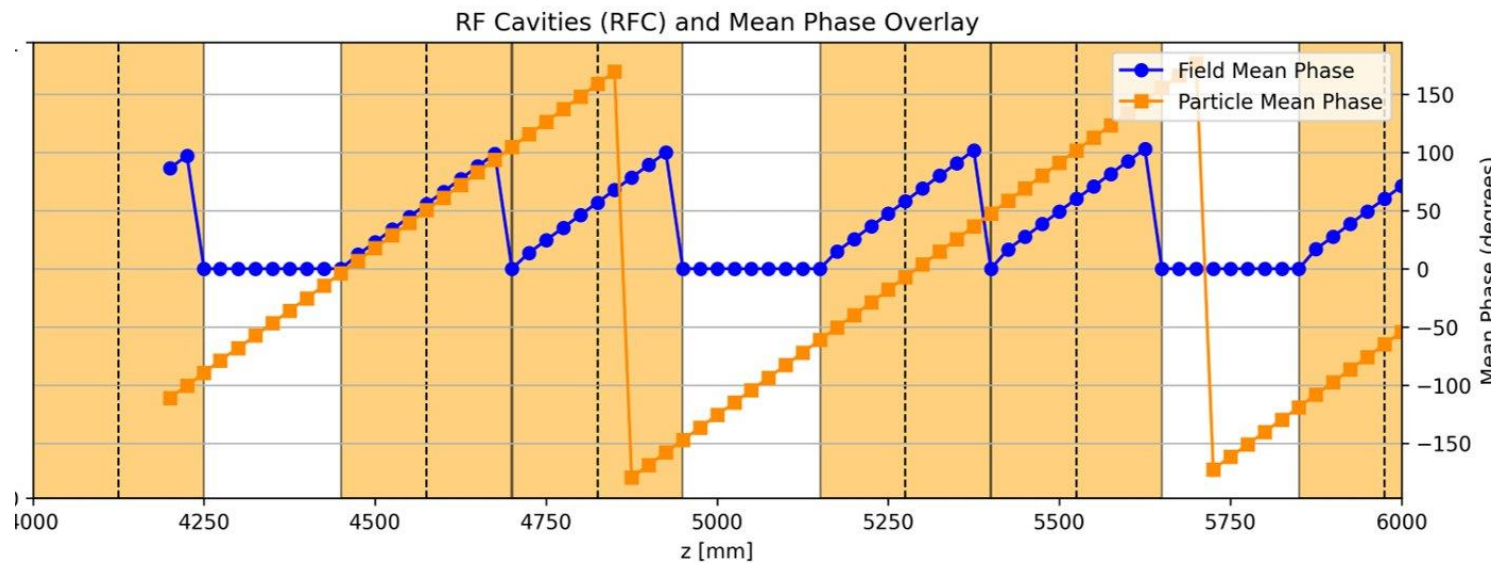

Muon Ionization Cooling – HFOFO

- Current roadblocks: Understanding differences between reference and synchronous particle and their trajectories to figure out if we need to include this timing in RF phase calculation (Daisy, Rithika)

Muon Ionization Cooling

- Areas of contribution:

- Currently, only the UTK group is working on HFOFO optimization projects; however, additional opportunities within HFOFO can be identified.
- Charge separator – HFOFO design is charge agnostic so the integration of initial and final cooling stages require charge separator (**under discussion with IMCC group**)

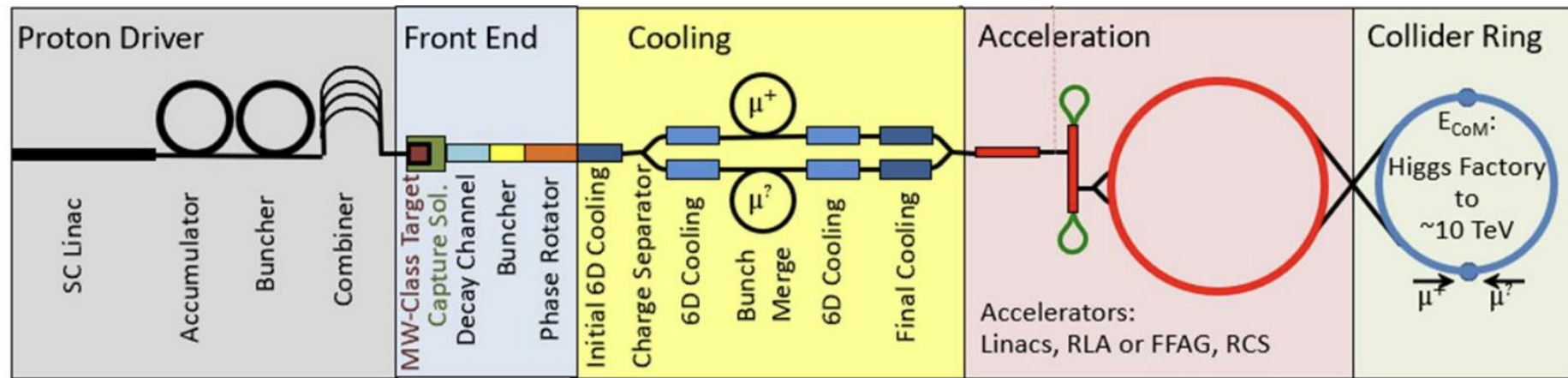

Neutrino Mitigation – Developing GEANT4 model

- Update (Daisy):
 - Neutrino physics is implemented and additional validation checks are going on.
 - Currently, only the neutrino electron processes are working as expected.

20 GeV electron

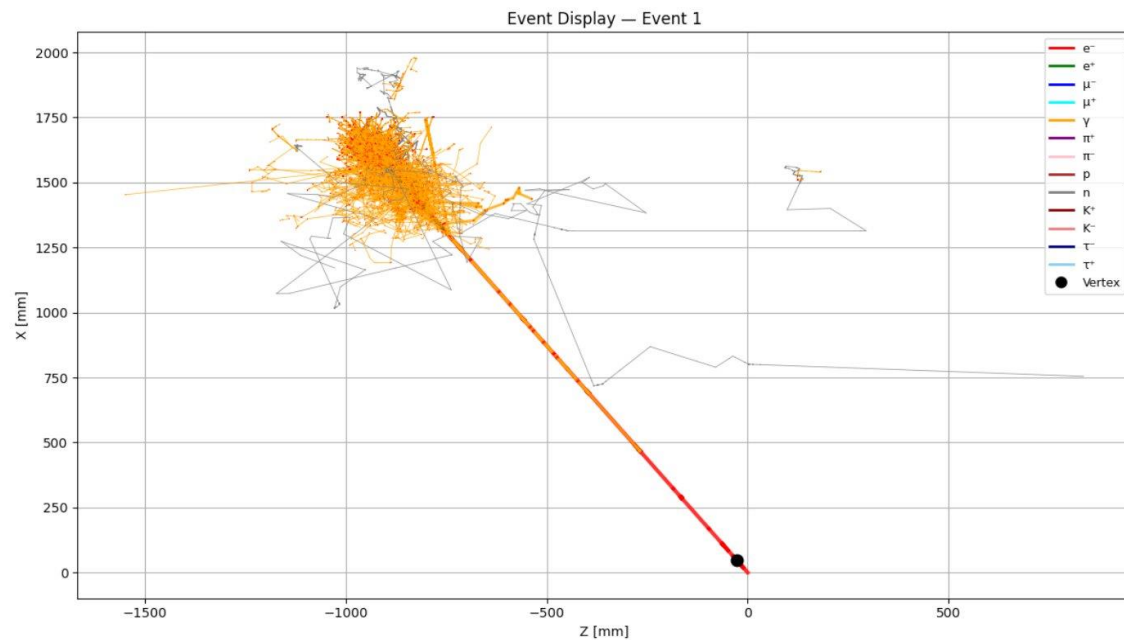

20 GeV electron-neutrino

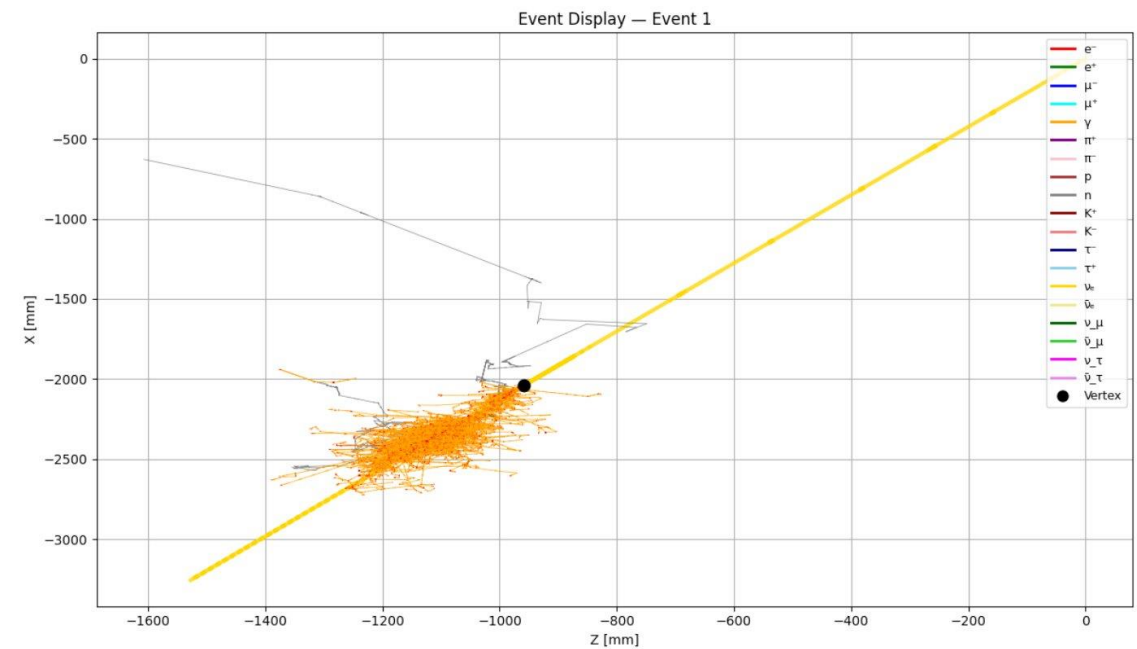

Neutrino Mitigation – Developing GEANT4 model

- Current roadblocks: Neutrino nucleus interactions in GEANT4 are currently causing simulation crashes, likely due to geometry and detector region configuration issues
 - Crashes at the first neutrino step
 - Error related to invalid nucleus parameters ($A=0, Z=0$)
 - Likely triggered when neutrinos interact with mixture materials or undefined regions

Neutrino Mitigation

- Areas of contribution:
 - Implementing neutrino-nucleus physics processes.
 - Exploring GENIE for neutrino interactions.
 - Integrate and analyze neutrino slice information in the model.