

Status Update

Daisy Kalra

Simons Team Meeting, May 08, 2026



Muon Ionization Cooling – HFOFO

- Understanding energy loss for reference and beam particle in G4beamline(Daisy)

	Reference particle	Beam, no stochastics	Beam, with stochastics	Reference, with stochastic	Bethe-Bloch
2.5 mm carbon absorber "tube" 200 MeV muon	3.24	3.24	3.27	In Progress	3.29
LiH wedge absorber HFOFO 200 MeV	1.72	1.72	1.73		1.73

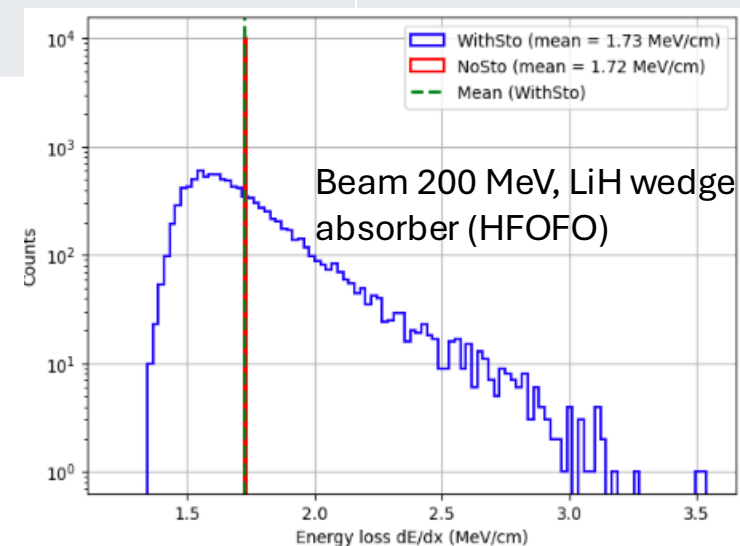
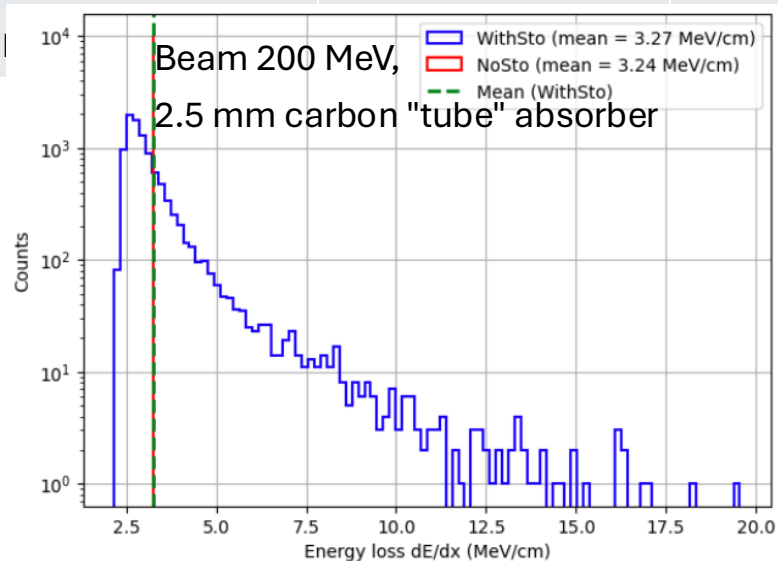

Muon Ionization Cooling – HFOFO

- Understanding energy loss for reference and beam particle in G4beamline(Daisy)

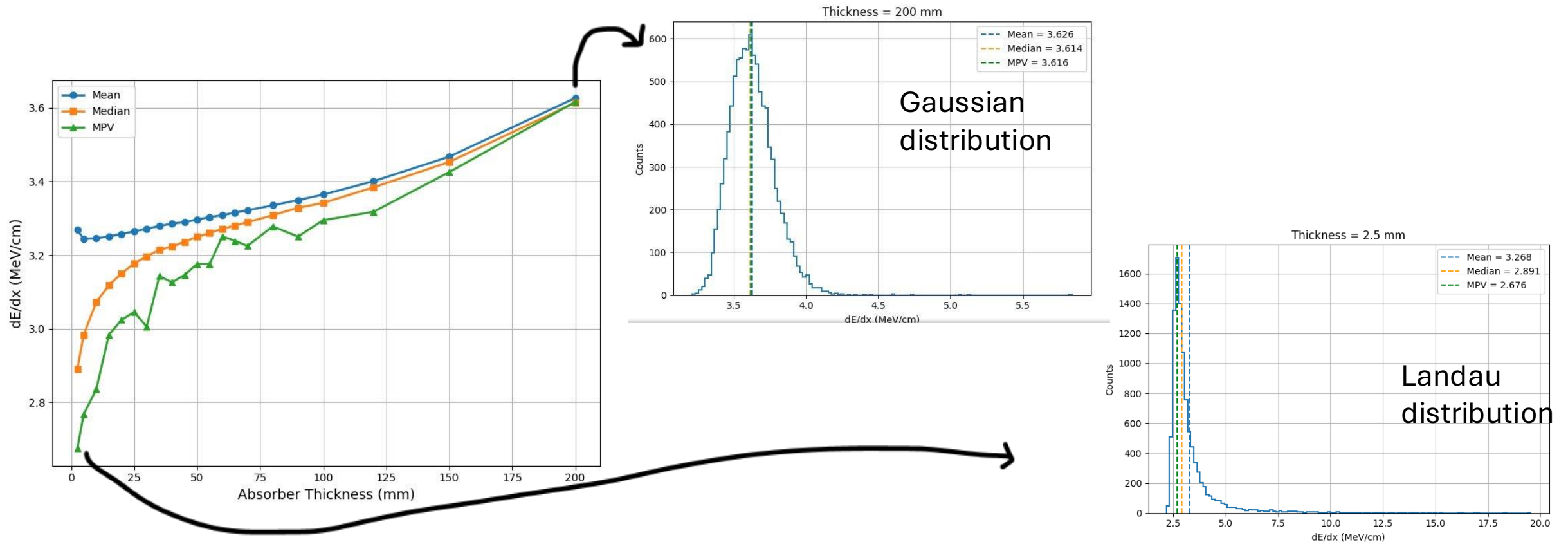

Muon Ionization Cooling – HFOFO

- Understanding energy loss for reference and beam particle in G4beamline(Daisy)
- Optimizing timing offsets and RF phase using reference particle (Rithika)

Using reference particle to tune RF cavity phase.
Achieved single particle matching within matching section and exploring other ways for tuning.

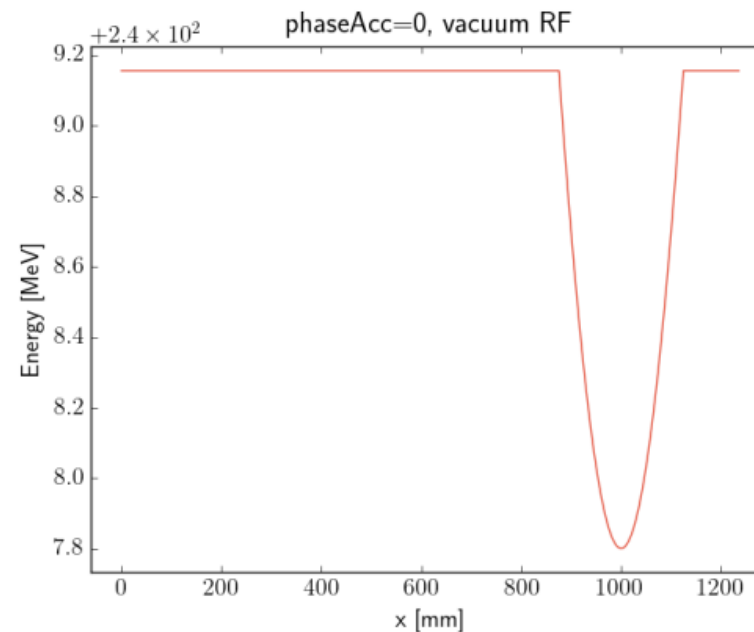

Muon Ionization Cooling – HFOFO

- Understanding energy loss for reference and beam particle in G4beamline(Daisy)
- Optimizing timing offsets and RF phase using reference particle and studying beam behavior by varying timing offsets(Rithika)

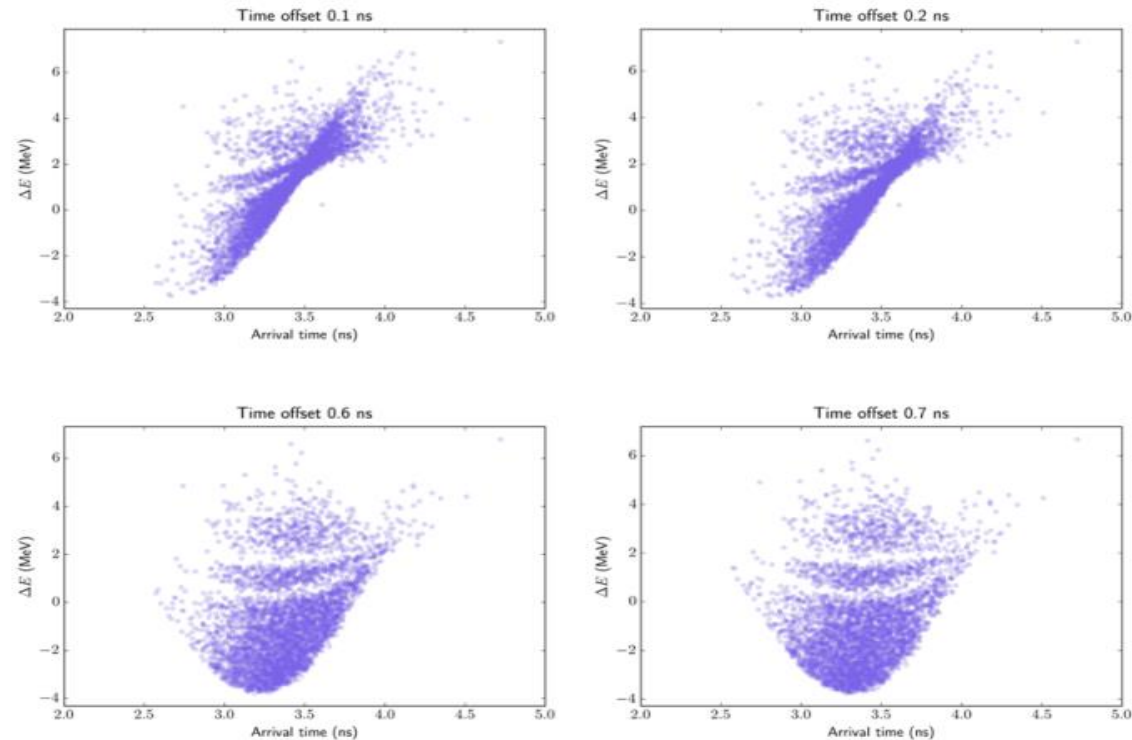

Muon Ionization Cooling – HFOFO

- ~~Current roadblocks~~ Unresolved questions -
 - What drives the observed beam behavior?
 - Whether the RF matching should be done using a single reference particle or using beam dynamics?
- Next steps and areas of contribution-
 - Implementing a reference particle with stochastics ON --> Daisy
 - Putting together all the components and run a complete pipeline --> Rithika

Neutrino Mitigation – Developing GEANT4 model

- Update (Daisy):
 - Neutrino physics is **fully** implemented in GEANT4 (v4.11.1) and validation checks are going on.

NuNucleusBias: 1e10
20 GeV ν_μ

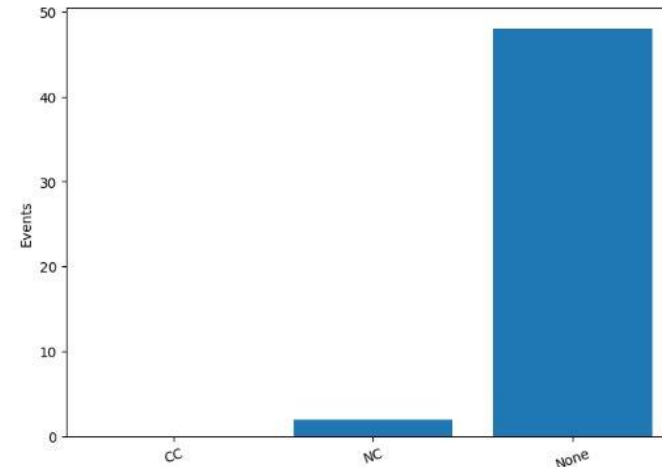
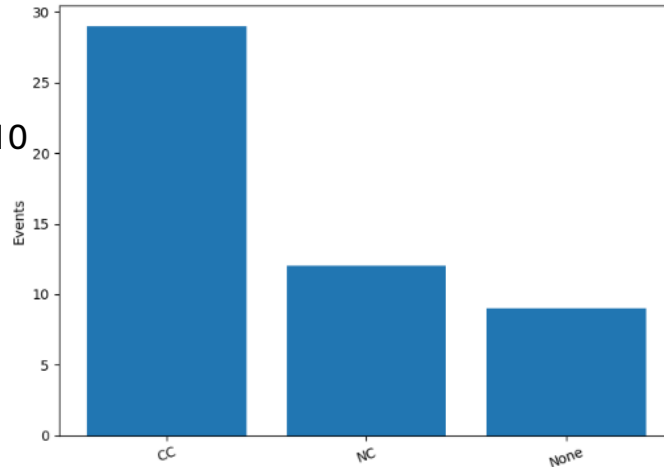

NuEleNCBias: 1e12
20 GeV ν_μ

NuNucleusBias: 1e10
20 GeV ν_e

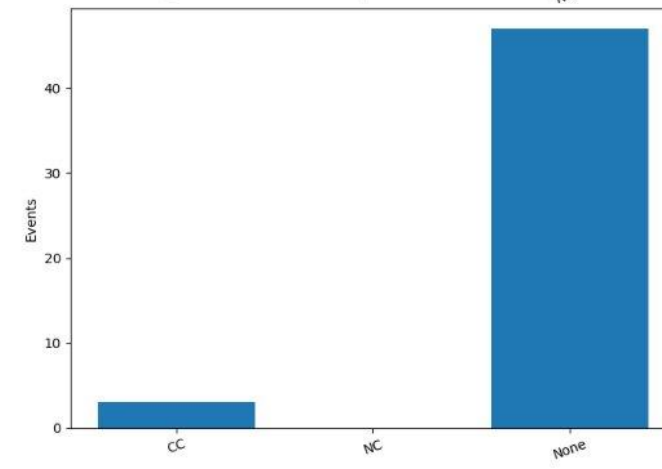
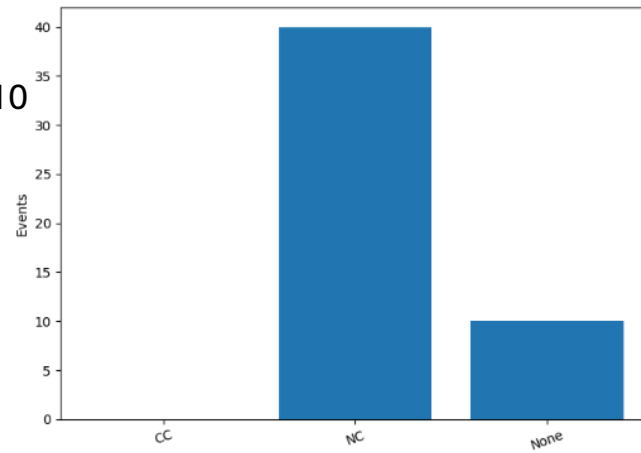

NuEleCCBias: 1e12
20 GeV ν_e

Neutrino Mitigation – Developing GEANT4 model

- Update (Daisy):
 - Neutrino physics is **fully** implemented in GEANT4 (v4.11.1) and validation checks are going on.

20 GeV ν_e NC event

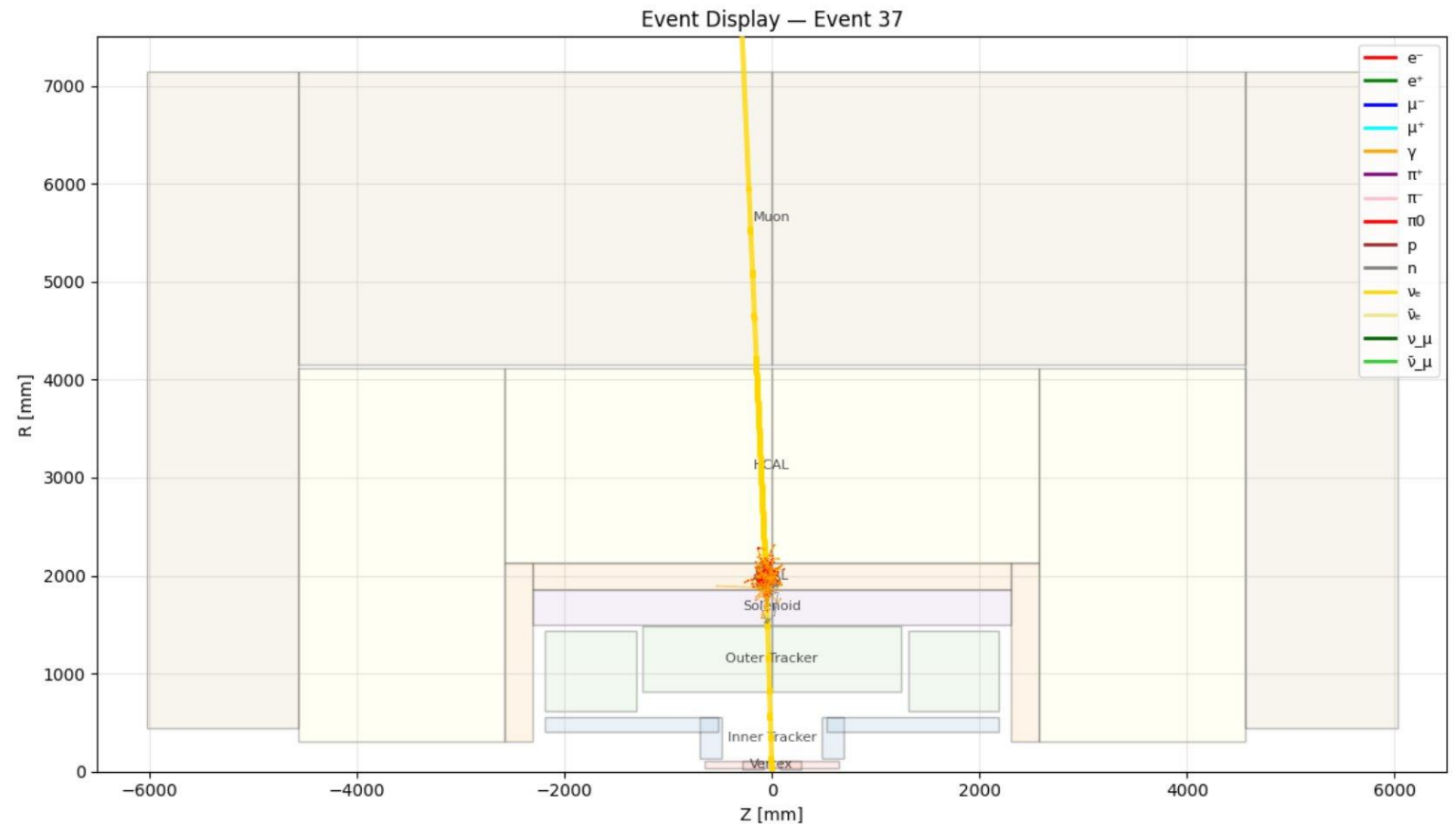

Neutrino Mitigation – Developing GEANT4 model

- Update (Daisy):
 - Neutrino physics is **fully** implemented in GEANT4 (v4.11.1) and validation checks are going on.

20 GeV ν_μ CC event

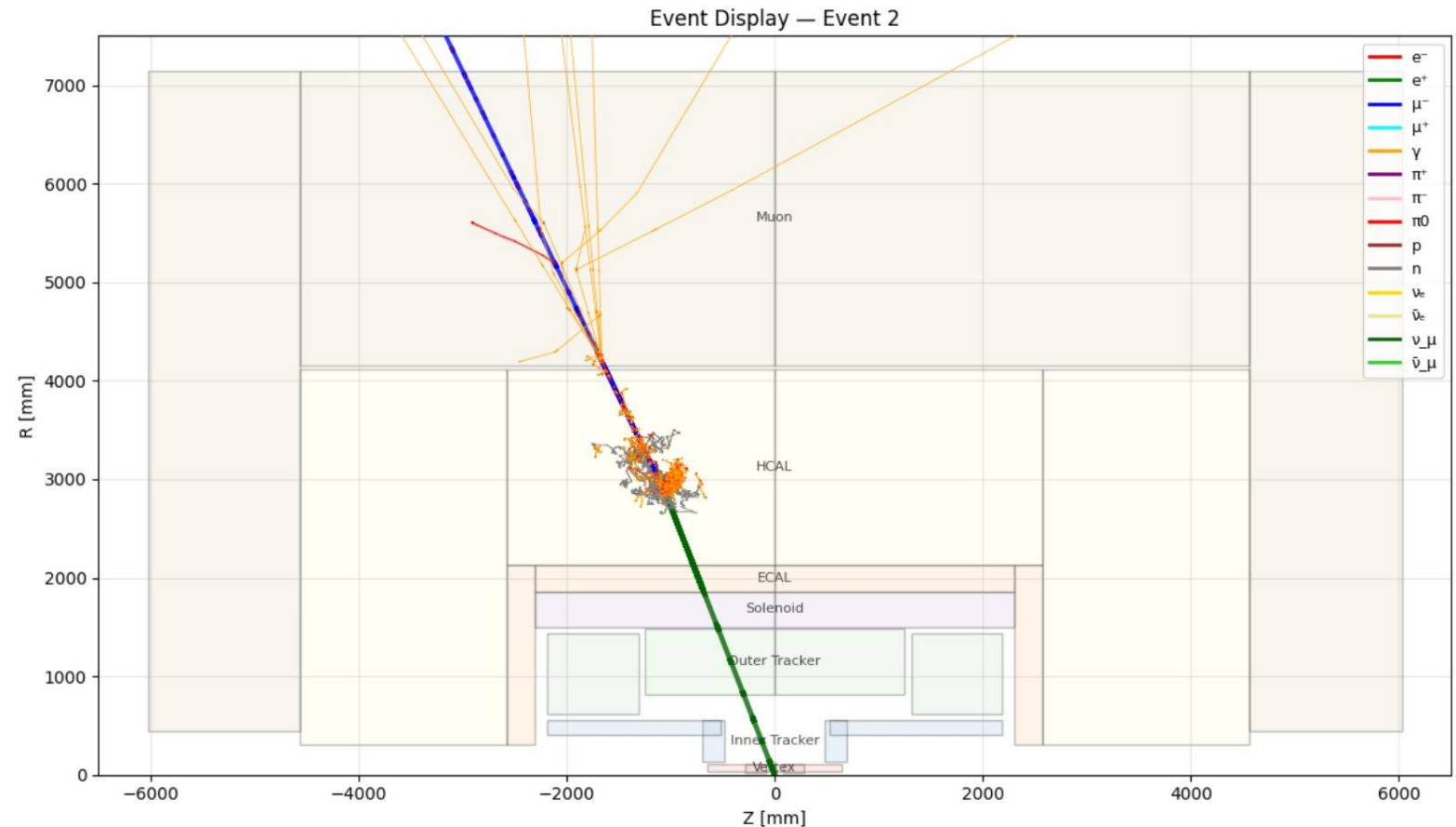

Neutrino Mitigation – Developing GEANT4 model

- Current roadblocks-

- Two of the neutrino biasing factors (NuEleCCBias for ν_μ and NuEleNCBias for ν_e) don't behave as expected (Need expert help.)

- Areas of contribution-

- Validation checks using independent samples with individual neutrino bias factors enabled --> analyzing ROOT files

- **Event-level information**

- Initial & final energy, total deposited energy, total secondary energy, event vertex position, hadronic energy

- **Study key neutrino interaction channels**

- Charged current, neutral current, quasi-elastic, resonance, deep inelastic

- **Understand kinematic variables**

- Energy transfer, momentum transfer...

- **Validate simulation outputs against expected physics distributions**

- Lepton energy spectra, angular distributions, secondary particle energies/multiplicities.

- **Track-level information**

- Track ID, Parent ID, Initial and final positions, track classification

- **Step-level information**

- Position, energy deposition, time, momentum
- Use this information to develop event displays

Previous presentations

Muon Ionization Cooling – HFOFO

From last week:

- **Current roadblocks: Understanding differences between reference and synchronous particle and**

- **Reorganized efforts**

- Studying average energy loss for reference particle and verify if tracking behavior agrees with Bethe-Bloch equation (Daisy)
- Studying time offsets and RF phase for reference and synchronous particle (Rithika)

Muon Ionization Cooling

- Areas of contribution:
 - Currently, only the UTK group is working on HFOFO optimization projects; however, additional opportunities within HFOFO can be identified.
 - Charge separator – HFOFO design is charge agnostic so the integration of initial and final cooling stages require charge separator (**under discussion with IMCC group**)

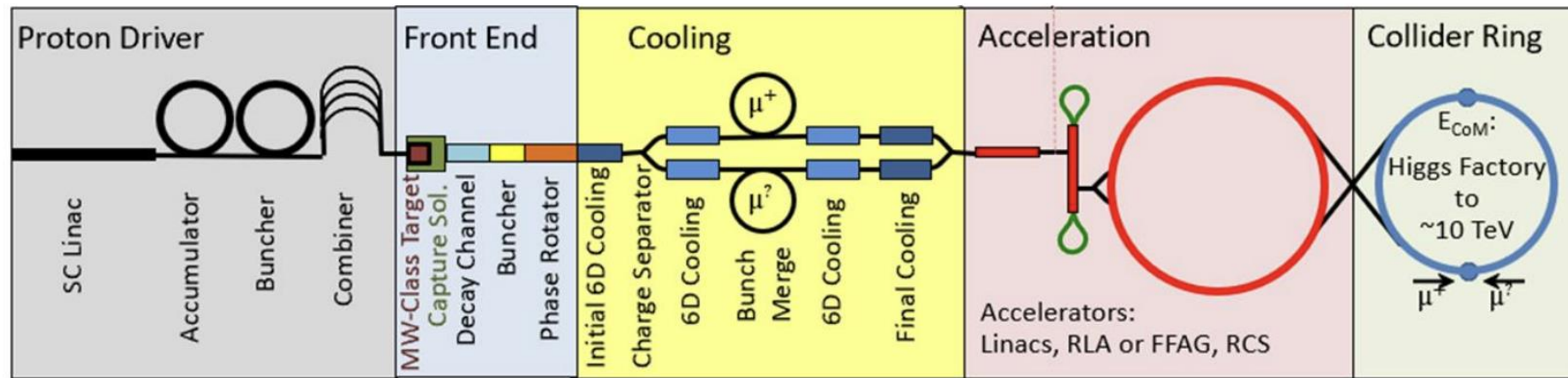

Neutrino Mitigation – Developing GEANT4 model

- Update (Daisy):
 - Neutrino physics is **fully** implemented in GEANT4 (v4.11.1) and validation checks are going on.

20 GeV muon-neutrino in
the MAIA detector

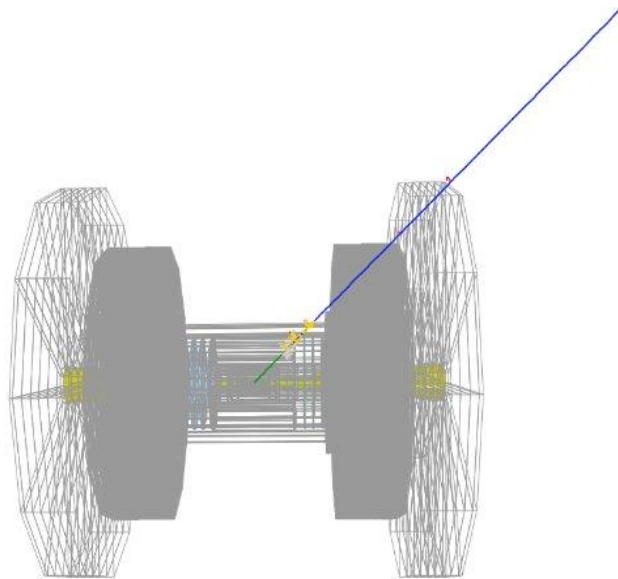

Detector Legend
Tracker (Azure)
Vertex (Green)
ECal (Magenta)
HCal (Blue)
Nozzle (Yellow)
Layer (Gray)
Component, slice (Gray)

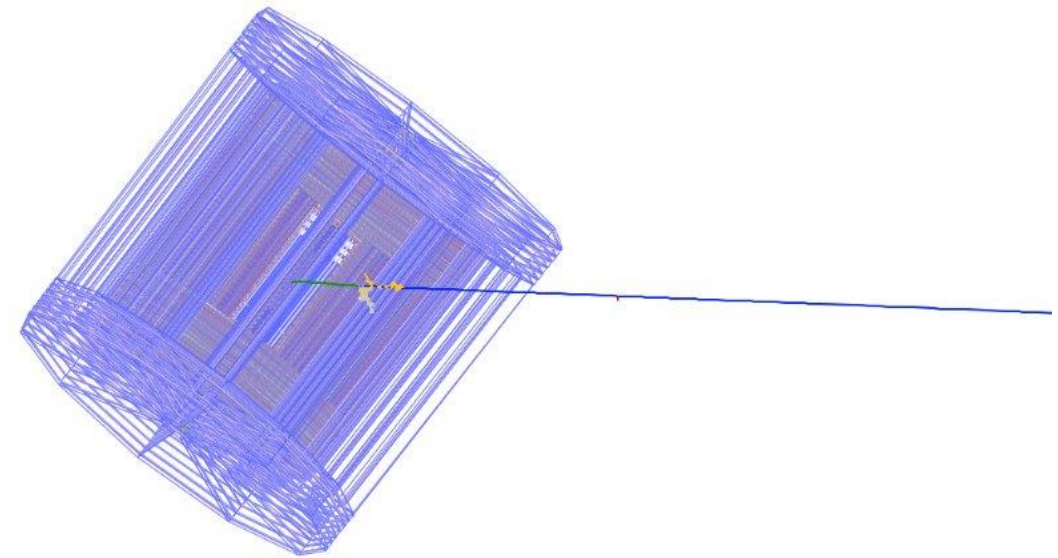

Neutrino Mitigation

- Areas of contribution:
 - Geometry visualizations and validation studies.
 - Exploring GENIE for neutrino interactions.
 - Integrate and analyze neutrino slice information in the model.

Status Update

Daisy Kalra

Simons Team Meeting, April 10, 2026



Muon Ionization Cooling – HFOFO

- Optimizing RF phase in G4beamline for the HFOFO lattice using field map (Daisy)
- Optimizing matching and cooling section by studying energy and momentum response (Rithika)

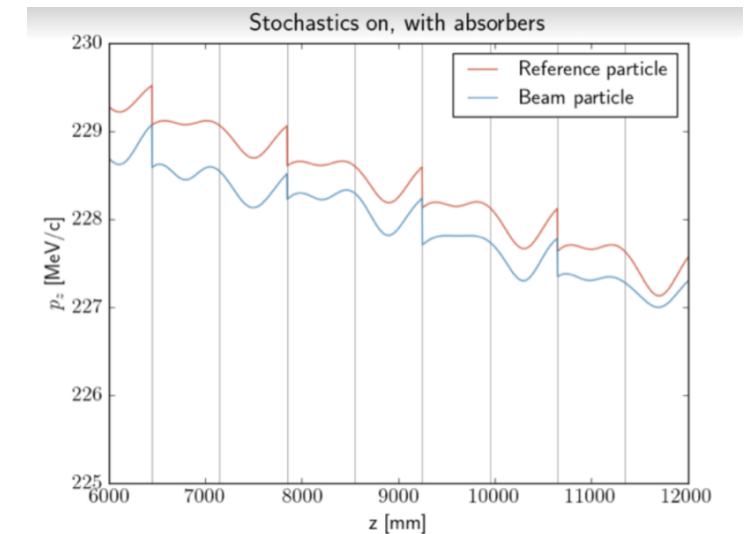
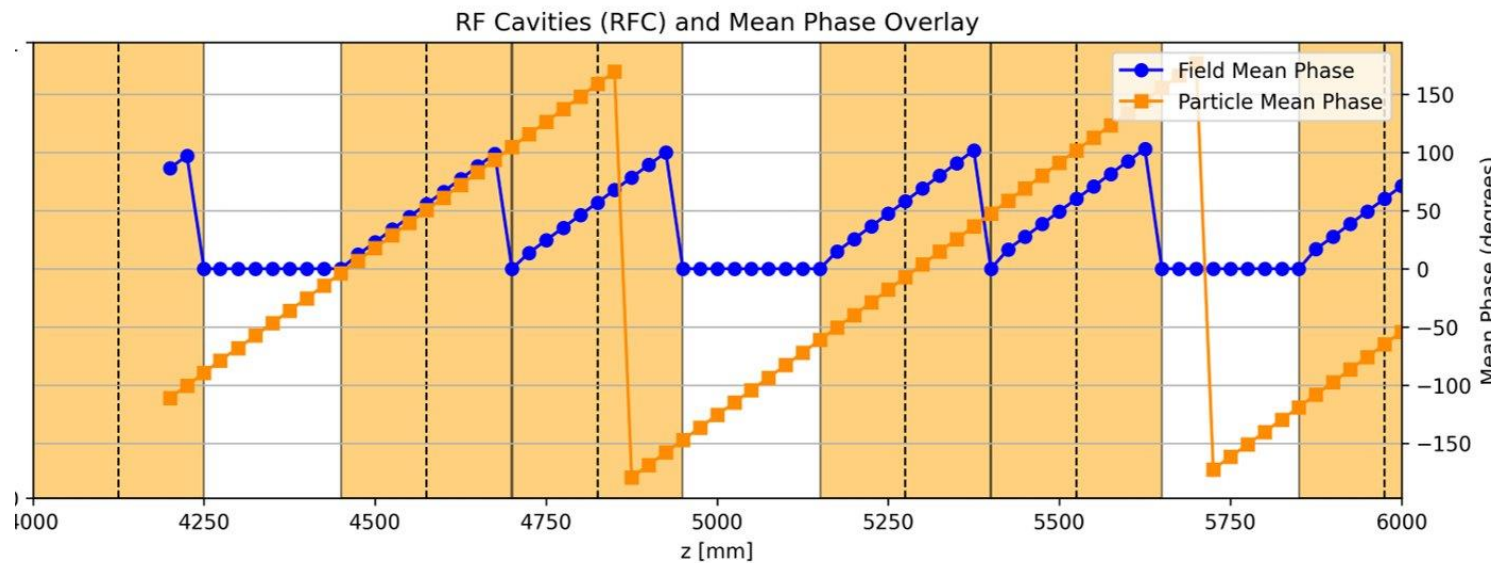

Muon Ionization Cooling – HFOFO

- Current roadblocks: Understanding differences between reference and synchronous particle and their trajectories to figure out if we need to include this timing in RF phase calculation (Daisy, Rithika)

Muon Ionization Cooling

- Areas of contribution:
 - Currently, only the UTK group is working on HFOFO optimization projects; however, additional opportunities within HFOFO can be identified.
 - Charge separator – HFOFO design is charge agnostic so the integration of initial and final cooling stages require charge separator (**under discussion with IMCC group**)

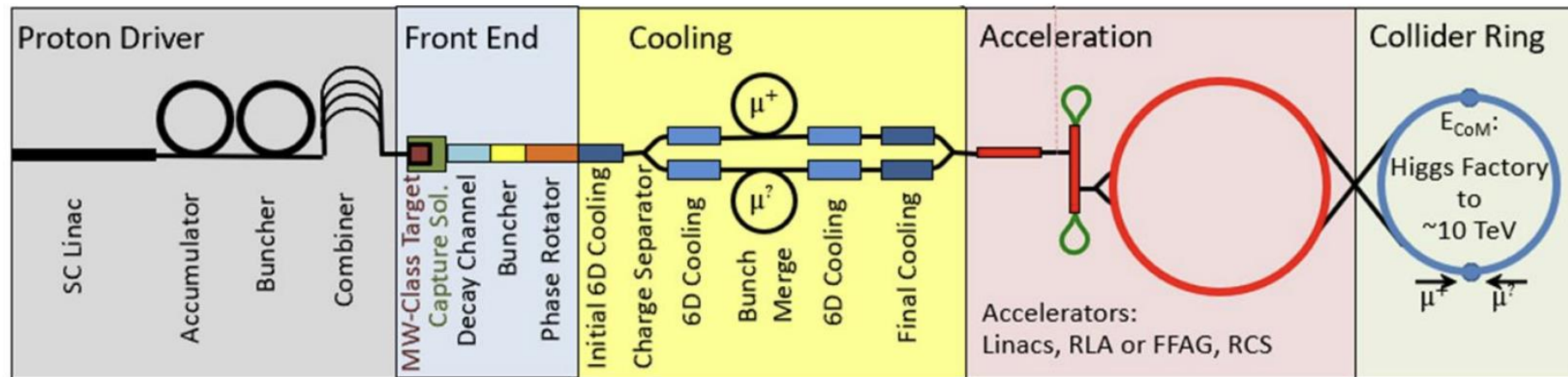

Neutrino Mitigation – Developing GEANT4 model

- Update (Daisy):
 - Neutrino physics is implemented and additional validation checks are going on.
 - Currently, only the neutrino electron processes are working as expected.

20 GeV electron

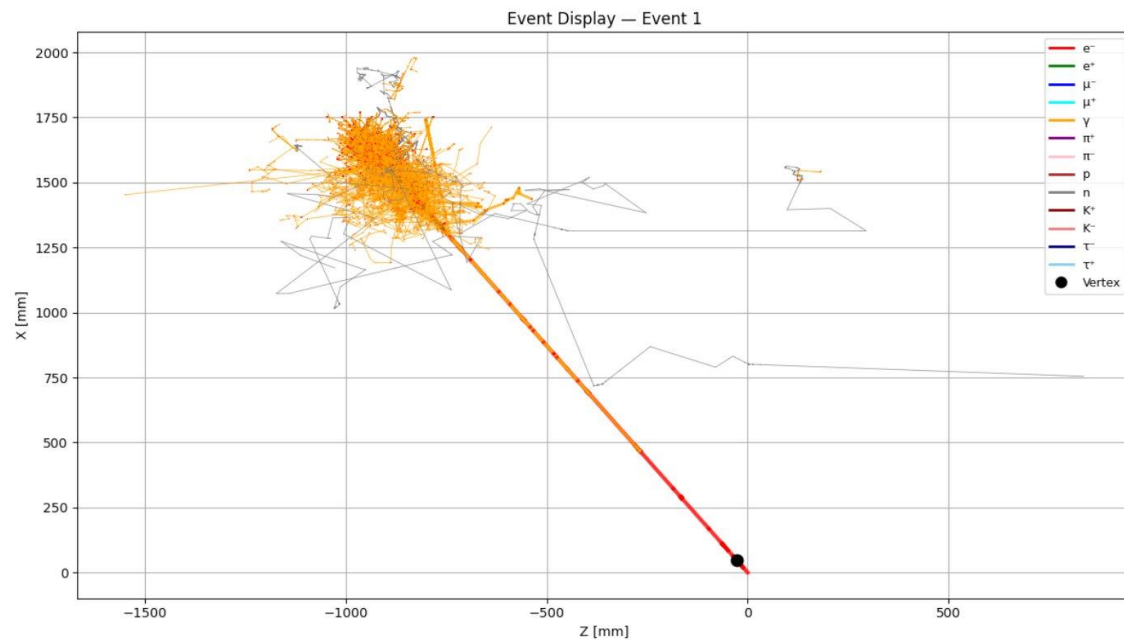

20 GeV electron-neutrino

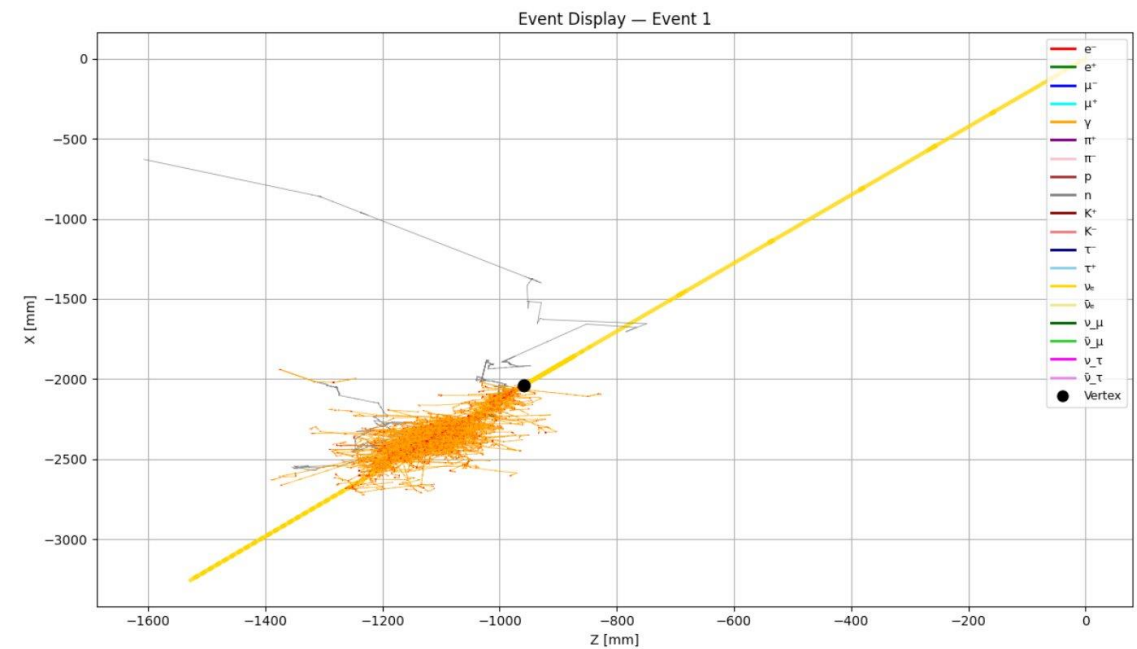

Neutrino Mitigation – Developing GEANT4 model

- Current roadblocks: Neutrino nucleus interactions in GEANT4 are currently causing simulation crashes, likely due to geometry and detector region configuration issues
 - Crashes at the first neutrino step
 - Error related to invalid nucleus parameters ($A=0, Z=0$)
 - Likely triggered when neutrinos interact with mixture materials or undefined regions

Neutrino Mitigation

- Areas of contribution:
 - Implementing neutrino-nucleus physics processes.
 - Exploring GENIE for neutrino interactions.
 - Integrate and analyze neutrino slice information in the model.

Status Update

Daisy Kalra

Simons Team Meeting, March 27, 2026



Muon Ionization Cooling – HFOFO

- Optimizing RF phase in G4beamline for the HFOFO lattice using field map (Daisy)
 - Extract the actual RF phase from electric field values in and around RF cavities.
 - Compare it to particle RF phase (from its arrival time in the cavity) and reinterpret the phase.
- Optimizing matching and cooling section (Rithika)
 - Studying energy and momentum response with and without stochastics and absorbers.
 - Exploring ML algorithms for matching section.

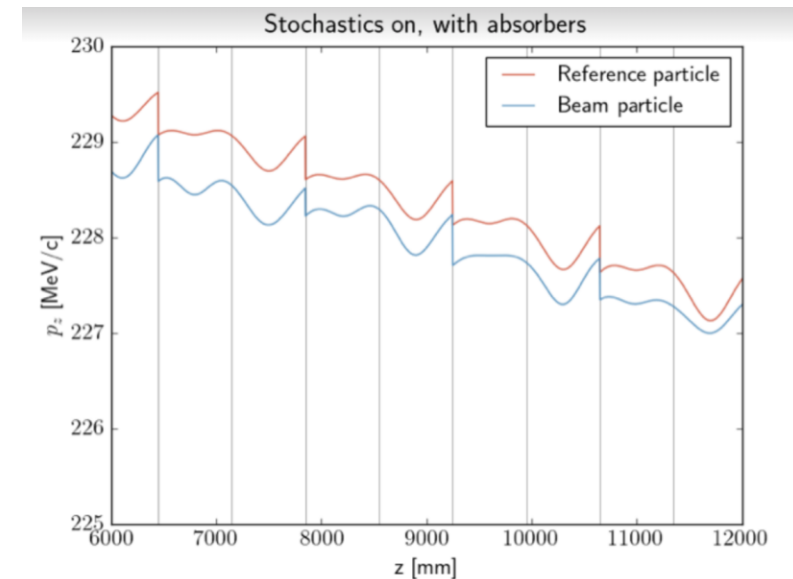
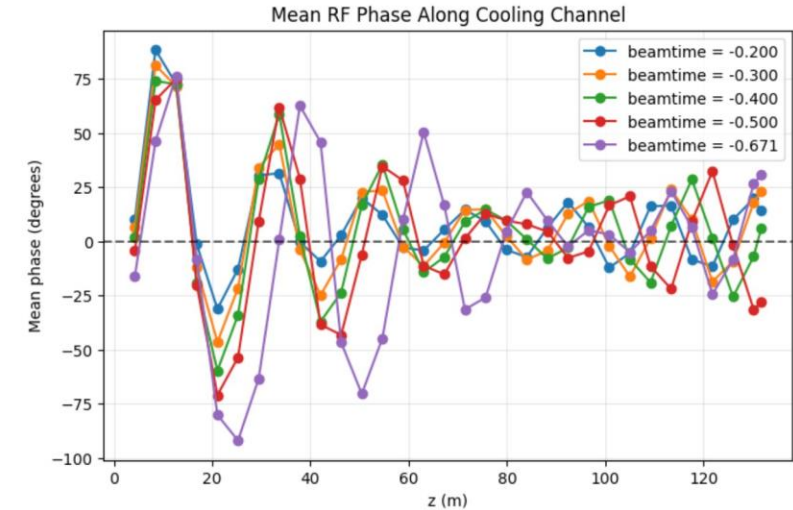

Muon Ionization Cooling

- Areas of contribution:

- Currently, only the UTK group is working on HFOFO optimization projects; however, additional opportunities within HFOFO can be identified.
- Charge separator – HFOFO design is charge agnostic so the integration of initial and final cooling stages require charge separator.

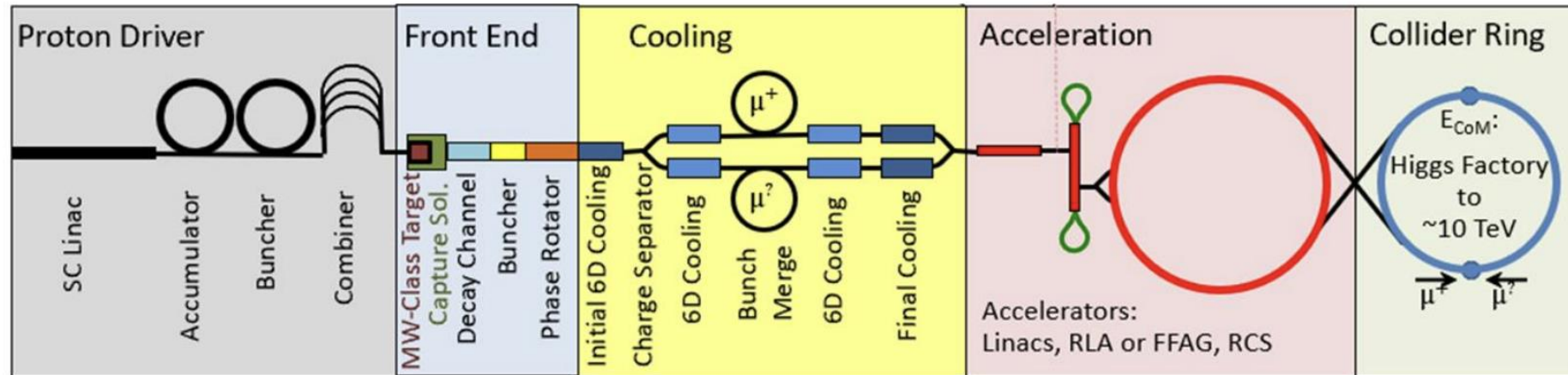

Neutrino Mitigation – Developing GEANT4 model

- Update (Daisy):
 - Neutrino physics is implemented and well validated within GEANT4. An example validation is shown; additional checks were performed for both primary and secondary particles.

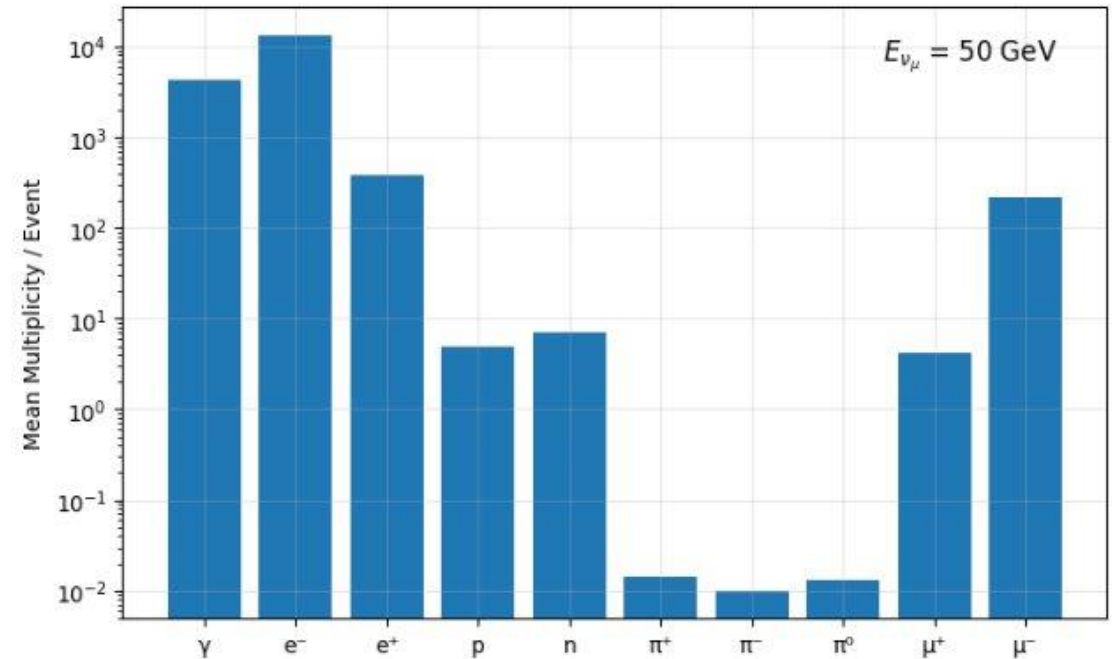
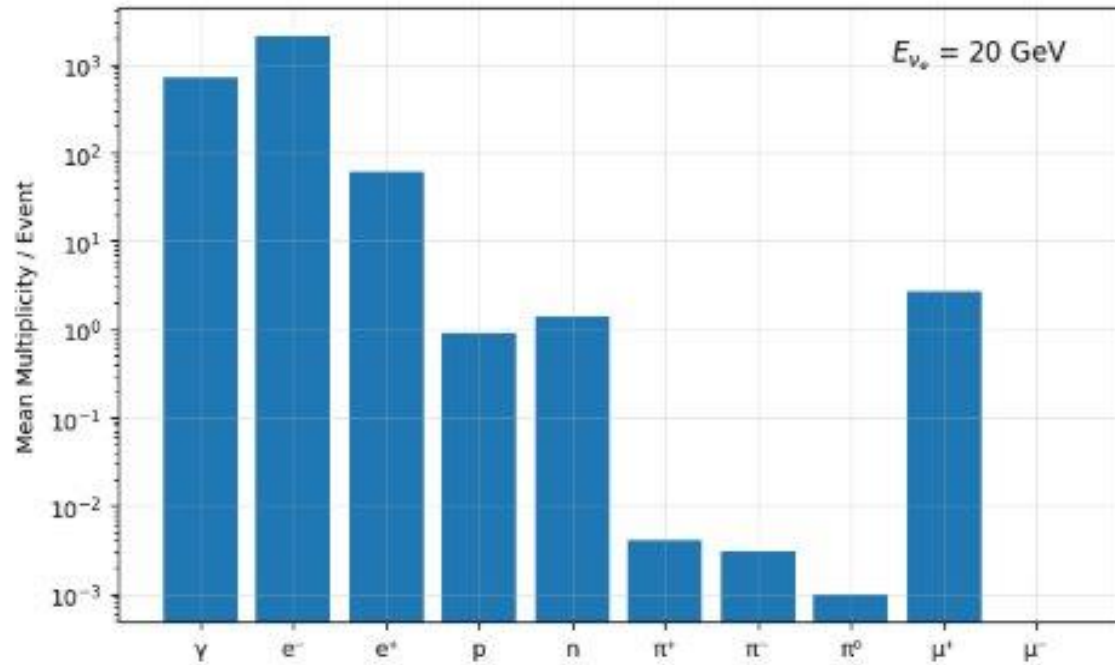

Neutrino Mitigation

- Areas of contribution:
 - Extending the program to include more information on primary and secondary particles.
 - Exploring GENIE for neutrino interactions.
 - Integrate and analyze neutrino slice information in the model.

Status Update

Daisy Kalra

Simons Team Meeting, March 13, 2026



Muon Ionization Cooling

- Muon ionization cooling channel –
 - HFQFO snake for initial 6D cooling of muons.
 - Reproduced many plots originally documented [here](#) from Yuri.
 - **Immediate goal** is to reproduce the remaining plots from Yuri and understand key parameters of the HFQFO channel (beam parameters, RF cavities).
 - **Long term goal** is to build a framework that integrates **initial 6D cooling with later final cooling stages**.

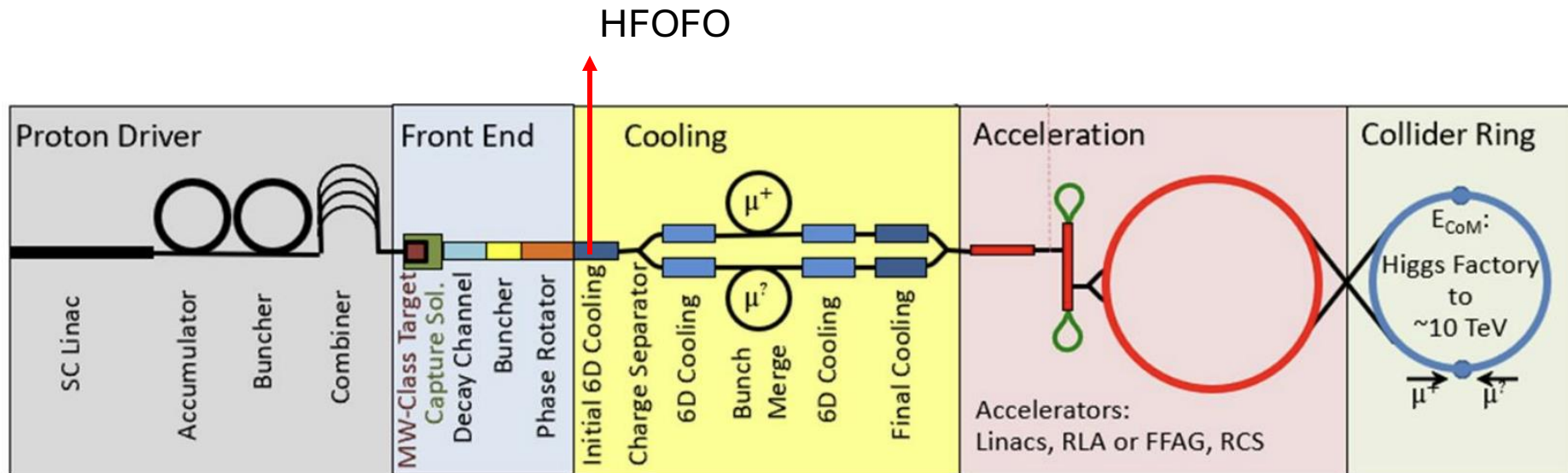

Muon Ionization Cooling

- Current status:
 - Focusing on how RF timing (including offsets) affects the beam behavior in the cooling channel. (Daisy)
 - Understanding how beamtime and timing offsets are set in the simulation. (Daisy)
 - Optimizing these parameters to study their effect on beam momentum and RF phase evolution. (Daisy)
 - Exploring ML algorithms for matching section (Rithika)
 - Studying RF timing offsets in matching section (Rithika)

```
param beamtime=-0.671
param toffs0=$beamtime-$beamstart/275.79 -0.07

param toffs1=$toffs0-.061-.0026+.0115+.006 # ti
param toffs2=$toffs1-.064+.149-.0052-.0029
param toffs3=$toffs2
param toffs4=$toffs3
param toffs5=$toffs4-.008
param toffs6=$toffs5
```

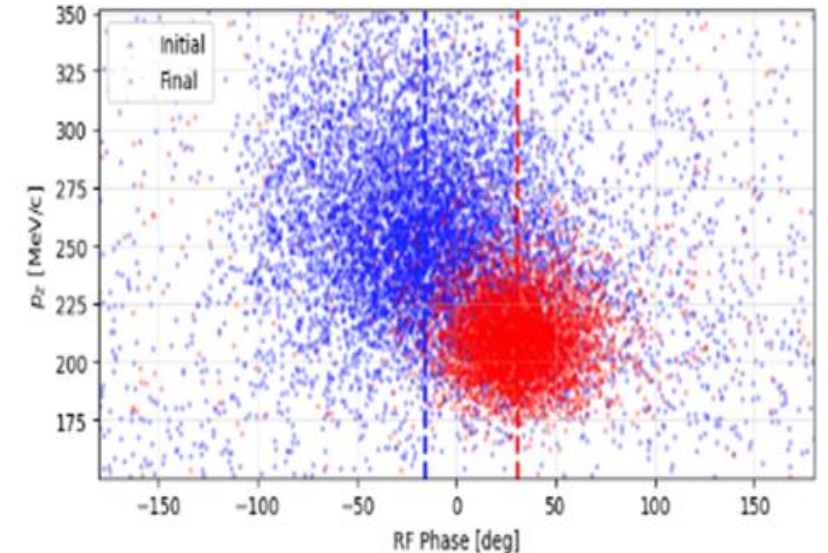

Particles at the **beginning** and **end** of HFOFO cooling channel
Ideally, the mean phase should stay same as the particles travel along the channel

Muon Ionization Cooling

- Areas of contribution:
 - Charge separator – HFOFO design is charge agnostic so the integration of initial and final cooling stages require charge separator.
 - ...

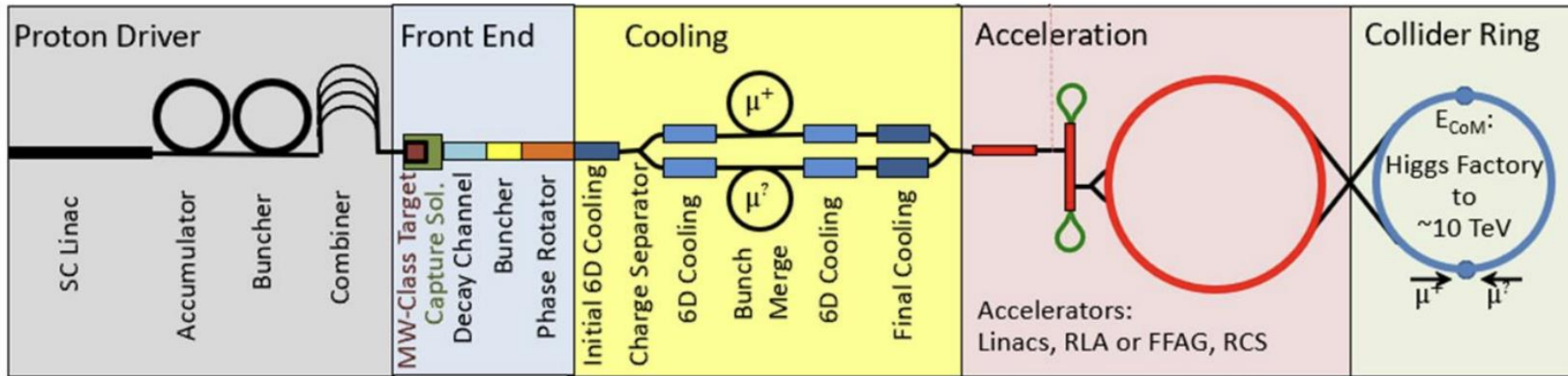

Neutrino Mitigation

- Immediate goal is to study neutrino interactions in the MAIA detector specifically in context of [Neutrino Slice](#) so as to explore ways to reduce them

Muon colliders provide an exciting new direction to expand the energy frontier of particle physics. We point out a new use of these facilities for neutrino and beyond the Standard Model physics *using their main detectors*. Muon decays along the accelerator rings create an intense and highly collimated neutrino beam that crosses a thin slice of the kt-scale detector. As a result, it would induce an unprecedented number of neutrino interactions, with $\mathcal{O}(10^4)$ events per second for a 10 TeV $\mu^+\mu^-$ collider. These interactions are highly energetic and possess a distinct timing signature and a large transverse displacement. We discuss promising applications of these events for instrumentation, electroweak, and beyond-the-Standard Model physics. For instance, a sub-percent measurement of the neutrino-electron scattering rate enables new precision measurements of the Weak angle and a novel detection of the neutrino charge radius.

Neutrino Mitigation

- Current status (Daisy):

- A generic GEANT model has been developed and validated by simulating electrons, protons, and muons.
- Neutrino physics has been implemented and is partially working; debugging and further validation checks are currently in progress.

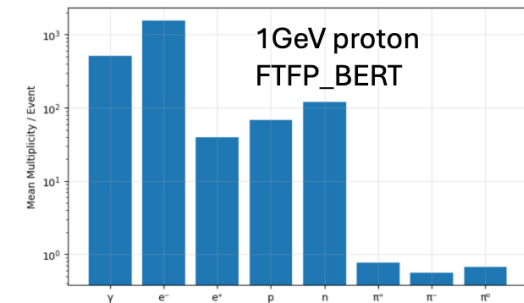
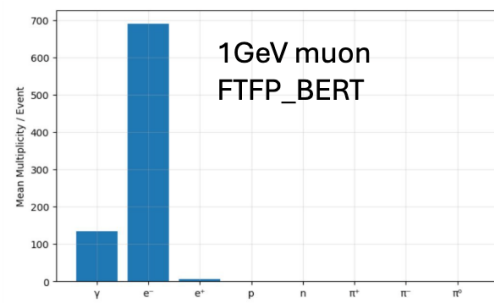
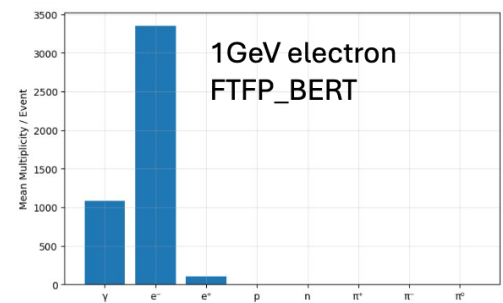

- Neutrino physics implementation is partially working

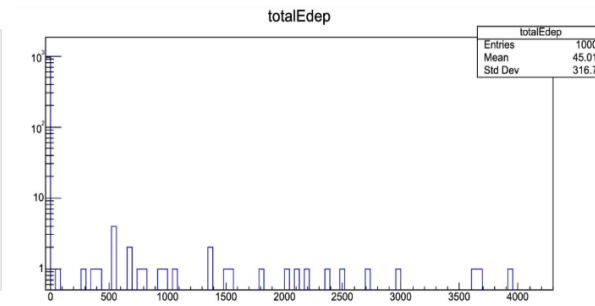
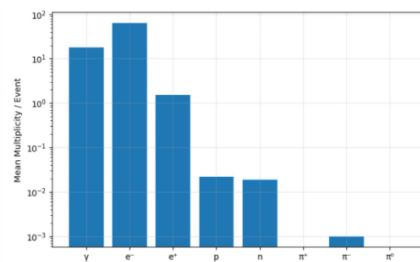

Neutrino Mitigation

- Areas of contribution:
 - Perform validation checks of neutrino physics through GEANT4 simulations.
 - Extending the program to include more information on primary and secondary particles.
 - Integrate and analyze neutrino slice information in the model.
 -

✓ <input type="checkbox"/> ROOT Files	
✓ <input type="checkbox"/> electron.root	<input type="checkbox"/> nProtonSec
✓ <input checked="" type="checkbox"/> tree;1	<input type="checkbox"/> nSecondaries
<input type="checkbox"/> E	<input type="checkbox"/> nSteps
<input type="checkbox"/> costh	<input type="checkbox"/> phi
<input type="checkbox"/> finalE	<input type="checkbox"/> px
<input type="checkbox"/> finalX	<input type="checkbox"/> py
<input type="checkbox"/> finalY	<input type="checkbox"/> pz
<input type="checkbox"/> finalZ	<input type="checkbox"/> secFirstZ
<input type="checkbox"/> nBackward	<input type="checkbox"/> secLastZ
<input type="checkbox"/> nCompton	<input type="checkbox"/> secMeanE
<input type="checkbox"/> nElectron	<input type="checkbox"/> secTotalE
<input type="checkbox"/> nGamma	<input type="checkbox"/> secTrackLength
<input type="checkbox"/> nIonisation	<input type="checkbox"/> theta
<input type="checkbox"/> nNeutron	<input type="checkbox"/> totalEdep
<input type="checkbox"/> nPairProd	<input type="checkbox"/> x
<input type="checkbox"/> nPionMinus	<input type="checkbox"/> y
<input type="checkbox"/> nPionPlus	<input type="checkbox"/> z
<input type="checkbox"/> nPionZero	
<input type="checkbox"/> nPositron	