

FLUKA + BIB slicing update

*(or, a brief-ish unraveling of **Daniele's BIB code**)*

Simons team meeting

8 May 2026

John (JP) Dervan
U. Tennessee, Knoxville



THE UNIVERSITY OF
TENNESSEE
KNOXVILLE

Status + roadmap



Some thoughts

- Hit a bit of a wall in understanding the simplified FLUKA BPE setup with neither a familiar geometry nor a deep understanding of FLUKA's structure
- Currently in literature review to compare FLUKA simulation approach vs Geant4... but even this amounts to many rabbit holes at once
- Solution: crack open Daniele's BIB code to understand FLUKA's structure. This helps...
 - prepare for the upcoming FLUKA workshop, and
 - start answering/informing some of our FLUKA and BIB slicing questions

Simulation - Smarter BIB slicing

- 1 month:** Able to compare parent muon properties to sim hits
- 2 months:** Parent muon properties identified
- 3 months:** Plan made for FLUKA simulation with new scheme

Simulation - FLUKA/Geant comparisons

- 1 month:** Available inputs assessed
- 2 months:** FLUKA results replicated
- 3 months:** Nozzle interactions compared

Overview

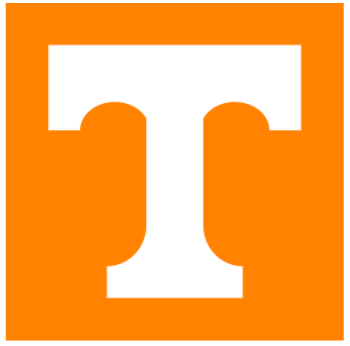

Repository @ CERN GitLab

- Can be found at <https://gitlab.cern.ch/dcalzola/mucoll-mdi-simulation-lattice-0.8>
- Plug-and-play FLUKA input file + executables

Overview



Repository @ CERN GitLab

- Can be found at <https://gitlab.cern.ch/dcalzola/mucoll-mdi-simulation-lattice-0.8>
- Plug-and-play FLUKA input file + executables

Codebase structure

```
mucoll-mdi-simulation-lattice-0.8/
├── README.md
├── fluka_inputs/
│   ├── lattice_v_0p8_EU_BIB_.inp ..... Main input
│   ├── lattice_v_0p8_EU_BIB_.flair ..... FLAIR GUI project file
│   └── run/
│       └── TRAJb.dat ..... Trajectory + optics
├── src/exe_decay_and_scoring/
│   ├── Makefile ..... Build system
│   ├── source_linopt_muondec_v0.f ..... SOURCE routine: muon decay sampler
│   ├── mgdraw_in_noz_area.f ..... MGDRAW routine: detector boundary scoring
│   └── usrglo.f ..... USRGLO routine: bunch crossing ref time
```

Overview



Repository @ CERN GitLab

- Can be found at <https://gitlab.cern.ch/dcalzola/mucoll-mdi-simulation-lattice-0.8>
- Plug-and-play FLUKA input file + executables

Codebase structure

```
mucoll-mdi-simulation-lattice-0.8/
├── README.md
├── fluka_inputs/
│   ├── lattice_v_0p8_EU_BIB_.inp ..... Main input
│   ├── lattice_v_0p8_EU_BIB_.flair ..... FLAIR GUI project file
│   └── run/
│       └── TRAJb.dat ..... Trajectory + optics
├── src/exe_decay_and_scoring/
│   ├── Makefile ..... Build system
│   ├── source_linopt_muondec_v0.f ..... SOURCE routine: muon decay sampler
│   ├── mgdraw_in_noz_area.f ..... MGDRAW routine: detector boundary scoring
│   └── usrglo.f ..... USRGLO routine: bunch crossing ref time
```

- FORTRAN routines:
 - ▶ SOURCE: user-defined routine to define primary particle generation (position, direction, energy, type, weight), called once per primary history
 - ▶ MGDRAW: migration draw; trajectory + dumping routine, called throughout transport allowing recording/reacting to “anything”
 - “Anything” = each step, boundary crossings, interactions, etc
 - Can do custom scoring, geometry debugging, feeding data to external tools... lots of flexibility
 - ▶ USRGLO: called at beginning and end for initialization + writing summary output. Used for zero crossing time in Daniele’s setup.
- FLAIR: GUI front-end and post-processing tool for setting up input files, visualizing geometry + other analysis of results

Overview



Repository @ CERN GitLab

- Can be found at <https://gitlab.cern.ch/dcalzola/mucoll-mdi-simulation-lattice-0.8>

What does FLUKA do?

Codebase structure

mucoll-mdi-simulation-lattice-0.8/

```
├── README.md
├── fluka_inputs/
│   ├── lattice_v_0p
│   └── lattice_v_0p
├── /
├── TRAJb.dat
├── decay_an
├── Makefile
├── source_linop
├── mgdraw_in_no
├── usrglo.f
```

(BUILD)

RUN

For each of 2×10^9 primaries...

- SOURCE reads TRAJb.dat → CDF-samples* decay point along lattice
- Applies emittance smearing
- Decays muon $\mu^\pm \rightarrow e^\pm + \nu_e + \nu_\mu$
- FLUKA transports secondaries through lattice geometry
- MGDRAW fires at detector scoring boundary (black hole) and records everything about secondaries

OUTPUT

- DET_IP.dat: particle-by-particle list at detector interface
- USRBIN files: energy deposition maps
- FLUKA std summary output (stats, geometry echo, normalization info, scoring tables)

FORTTRAN routines:

- ▶ SOURCE: user-defined routine to define primary particle generation (position, direction, energy, type, weight), called once per primary history
- ▶ MGDRAW: migration draw; trajectory + dumping routine, called throughout transport allowing recording/reacting to “anything”
 - “Anything” = each step, boundary crossings, interactions, etc
 - Can do custom scoring, geometry debugging, feeding data to external tools... lots of flexibility
- ▶ USRGL0: called at beginning and end for initialization + writing summary output. Used for zero-crossing in Daniel's setup.

- FLAIR: GUI front-end and post-processing tool for setting up input files, visualizing geometry + other analysis of results

*CDF sampling appears to be a strictly flat distribution along the muon's traversed arclength—is this physical?

A closer look at the **primary inputs**



Main input: lattice_v_0p8_EU_BIB_.inp

- Default macro: decay → full BIB sim via forced muon decay
 - Default physics preset: PHYSICS_DECAY → 100 keV cutoff on EM particle transport, full EM showering, photonuclear ON
 - DEFAULTS defines **FLUKA card** with pre-configured collection of physics settings
 - *Very very roughly* similar in function to a G4 physics list
 - PRECISI0 used here—general purpose high-accuracy → PHYSICS_DECAY overrides specific settings/cuts
 - Full multiple Coulomb scattering at every step
 - Continuous energy loss with fluctuations
 - Delta ray production
 - Spin effects in muon transport
 - Low transport thresholds for hadrons (~1 MeV) before EMFCUT overrides for EM particles
 - Accurate curved-track integration in magnetic fields
- } *the works*
- BEAM/BEAMPOS
 - SOURCE: calls user source, passes emittance in $\mu\text{m}^*\text{rad}$ and $\Delta p/p$
 - GE0BEGIN→GE0END: Full lattice geometry expressed via boolean ops on primitives (combinatorial, cf. mesh). Dipoles, nozzles, beam pipe, shielding, detector volume
 - ASSIGNMA + MATERIAL: material definitions. Elements (W, B, Be,..), compounds (Nb3Sn, NbTi, stainless steel), cryogenic variants at 1.9/4/87K (thermal layer structure of SCM)
 - EMFCUT/PHOTONUC: physics cuts and PN reactions enabled
 - MGNFIELD: field maps for dipoles and quads
 - USRBIN: energy deposition scoring, region-averaged (not what we dump to DET_IP.dat)
 - START: unleash 2e9 primaries sequentially

What are we **recording** in MGDRAW?



At each boundary crossing, we write to DET_IP.dat...

JTRACK	Integer PID	WRITE(IODRAW) JTRACK, JMOTHE, ETRACK-AM(JTRACK), XSCO, YSCO, ZSCO, CXTRCK, CYTRCK, CZTRCK, ATRACK + AGESAMP - AGECSOS, XSAMP, YSAMP, ZSAMP
JMOTHE	PID of mother particle	
ETRACK-AM(JTRACK)	Particle KE at boundary	
XSCO, YSCO, ZSCO	Position of crossing point (cm)	
CXTRCK, CYTRCK, CZTRCK	Particle momentum direction unit vector	
ATRACK + AGESAMP - AGECSOS	Arrival time relative to BX	
XSAMP, YSAMP, ZSAMP	Parent muon decay location	

Are we leaving anything useful out?

- WTRACK: statistical weight of the particle → if we introduce biasing, this becomes important
- Primary muon index: An incremented counter should be relatively straightforward to add, modulo tweaks to parallelization
- MREG: current region → could be used to track+characterize particles not coming through the nozzles

Outlook



Open tasks/next steps:

- After FLUKA workshop + few immediate bug in the BH ironed out → run for a handful of events
- Validate outputs (...)
- A clear(er) mapping from FLUKA to G4 (particle outputs, geometry...) would open up a lot of study
 - Ultimately want to understand what can be passed off between FLUKA and G4
- Deep dive on FLUKA machinery—how are hadronic and EM-shower interactions handled differently (e.g. PEANUT vs G4 encoded had processes...)
 - Problem here is scope!
- Other thoughts?

Simulation - Smarter BIB slicing

- 1 month:** Able to compare parent muon properties to sim hits
- 2 months:** Parent muon properties identified
- 3 months:** Plan made for FLUKA simulation with new scheme

Simulation - FLUKA/Geant comparisons

- 1 month:** Available inputs assessed
- 2 months:** FLUKA results replicated
- 3 months:** Nozzle interactions compared

Thanks!

Backup: add'l macros, cards, and presets



- Macros:
 - ▶ Survey: kills EM showers + shortens step size for lattice validation
 - ▶ Load decay: load pre-generated BIB from files rather than regenerating
 - ▶ Halo: halo loss simulation, models beam particles lost to aperture rather than decay
 - ▶ SSEC/SUSRGLO: load IPP pairs from Guinea Pig
- Physics presets
 - ▶ Magnet: 1.25 MeV threshold for SC magnet dosing
 - ▶ Pairs: similar to decay but more general for pair backgrounds
 - ▶ Halo: spatially varying cuts, tighter near IP+detector, looser in outer regions
- Cards
 - ▶ Hadron therapy: accurate dose, low thresholds
 - ▶ Shielding: calculations optimized for penetrating radiation
 - ▶ Electron: electron/photon transport
 - ▶ New default: updated relative to PRECISIO
 - ▶ Calorimeter detectors
 - ▶ Energy and transmutation studies

Backup: TRAJb.dat contents



A description of the ideal muon

```

15 15.097764589760503 8.198006826667052e-06 0.0 -23984.963432936256 2.853583019834215e-14 0.0 1.0000000000000002 5.036072186022595e-10 2311.4382593816185 887.2557228019791 -199.49649158271163 -75.80846193852237 -1.0406119251040898e-05 0.0 5.658302576e-08 0.0 1.0 0.0 -2.8535830198342146e-14
16 16.097616549347293 8.198006854598662e-06 0.0 -23983.963580976648 2.853583019834215e-14 0.0 1.0000000000000002 5.369586900328722e-10 2315.429319897796 888.7723152262257 -199.66865260845384 -75.87323550750479 -1.0405553504556245e-05 0.0 5.658302576e-08 0.0 1.0 0.0 -2.8535830198342146e-14
17 17.0974685089341 8.198006883130273e-06 0.0 -23982.963729017047 2.853583019834215e-14 0.0 1.0000000000000002 5.703101614634851e-10 2319.423823124763 890.290202930074 -199.8408136341965 -75.93800907648738 -1.0404987758064388e-05 0.0 5.658302576e-08 0.0 1.0 0.0 -2.8535830198342146e-14
18 18.097320468520905 8.198006911661883e-06 0.0 -23981.96387705744 2.853583019834215e-14 0.0 1.0000000000000002 6.036616328940979e-10 2323.4217690624982 891.8093859135155 -200.01297465993875 -76.00278264546978 -1.0404422011572532e-05 0.0 5.658302576e-08 0.0 1.0 0.0 -2.8535830198342146e-14
19 19.09717242810771 8.198006940193493e-06 0.0 -23980.96402509784 2.853583019834215e-14 0.0 1.0000000000000002 6.370131043247108e-10 2327.423157711024 893.3298641765589 -200.18513568568144 -76.06755621445237 -1.040385626580868e-05 0.0 5.658302576e-08 0.0 1.0 0.0 -2.8535830198342146e-14
20 20.09702438769452 8.198006968725102e-06 0.0 -23979.964173138236 2.853583019834215e-14 0.0 1.0000000000000002 6.703645757553236e-10 2331.427989070318 894.8516377191954 -200.3572967114237 -76.13232978343477 -1.0403290518588824e-05 0.0 5.658302576e-08 0.0 1.0 0.0 -2.8535830198342146e-14
21 21.096876347281324 8.198006997256714e-06 0.0 -23978.964321178628 2.853583019834215e-14 0.0 1.0000000000000002 7.037160471859363e-10 2335.436263140401 896.374706541434 -200.52945773716635 -76.19710335241737 -1.040272477209697e-05 0.0 5.658302576e-08 0.0 1.0 0.0 -2.8535830198342146e-14
22 22.09672830686813 8.198007025788326e-06 0.0 -23977.964469219023 2.853583019834215e-14 0.0 1.0000000000000002 7.37067518616549e-10 2339.447979921253 897.8990706432656 -200.70161876298857 -76.26187692139978 -1.0402159025605114e-05 0.0 5.658302576e-08 0.0 1.0 0.0 -2.8535830198342146e-14
23 23.096580266454936 8.198007054319934e-06 0.0 -23976.964617259415 2.853583019834215e-14 0.0 1.0000000000000002 7.704189900471619e-10 2343.463139412895 899.4247300246991 -200.8737797886513 -76.32665049038236 -1.040159327911326e-05 0.0 5.658302576e-08 0.0 1.0 0.0 -2.8535830198342146e-14
24 24.096432226041745 8.198007082851544e-06 0.0 -23975.964765299814 2.853583019834215e-14 0.0 1.0000000000000002 8.037704614777748e-10 2347.4817416153046 900.9516846857258 -201.04594081439348 -76.39142405936477 -1.0401027532621403e-05 0.0 5.658302576e-08 0.0 1.0 0.0 -2.8535830198342146e-14
25 25.096284185628548 8.198007111383153e-06 0.0 -23974.96491334021 2.853583019834215e-14 0.0 1.0000000000000002 8.371219329083876e-10 2351.503786528505 902.4799346263544 -201.21818184013617 -76.45619762834737 -1.040046178612955e-05 0.0 5.658302576e-08 0.0 1.0 0.0 -2.8535830198342146e-14
26 26.096136145215358 8.198007139914767e-06 0.0 -23973.965061380604 2.853583019834215e-14 0.0 1.0000000000000002 8.704734043390005e-10 2355.5292741524727 904.0094798465764 -201.3902628658784 -76.52097119732977 -1.0399896039637695e-05 0.0 5.658302576e-08 0.0 1.0 0.0 -2.8535830198342146e-14
27 27.09598810480216 8.198007168446375e-06 0.0 -23972.965209421 2.853583019834215e-14 0.0 1.0000000000000002 9.038248757696131e-10 2359.558204487231 905.5403203464 -201.56242389162108 -76.58574476631236 -1.039933029314584e-05 0.0 5.658302576e-08 0.0 1.0 0.0 -2.8535830198342146e-14
28 28.09584006438897 8.198007196977985e-06 0.0 -23971.965357461395 2.853583019834215e-14 0.0 1.0000000000000002 9.371763472002262e-10 2363.590577532757 907.0724561258168 -201.7345849173633 -76.65051833529476 -1.0398764546653986e-05 0.0 5.658302576e-08 0.0 1.0 0.0 -2.8535830198342146e-14
29 29.09569202397577 8.19800722509596e-06 0.0 -23970.965505501794 2.853583019834215e-14 0.0 1.0000000000000002 9.70527818630839e-10 2367.6263932890733 908.6058871848354 -201.906745943106 -76.71529190427735 -1.039819880016213e-05 0.0 5.658302576e-08 0.0 1.0 0.0 -2.8535830198342146e-14
30 30.095543983562575 8.198007254041206e-06 0.0 -23969.965653542185 2.853583019834215e-14 0.0 1.0000000000000002 1.0038792900614519e-09 2371.6656517561573 910.1406135234474 -202.0789069688482 -76.78006547325977 -1.0397633053670276e-05 0.0 5.658302576e-08 0.0 1.0 0.0 -2.8535830198342146e-14
    
```

(Disgusting.)

Column	Contents
1	Arc length s (cm)
2-4	Position in xyz (cm)
5-7	Direction cosines u_x, u_y, u_z
8	Particle age (s)
9-12	Twiss parameters β and α (m)
13-16	Dispersion D_x, D_y and derivatives
17-19	Twiss coordinate system director cosines

Backup: FLUKA map

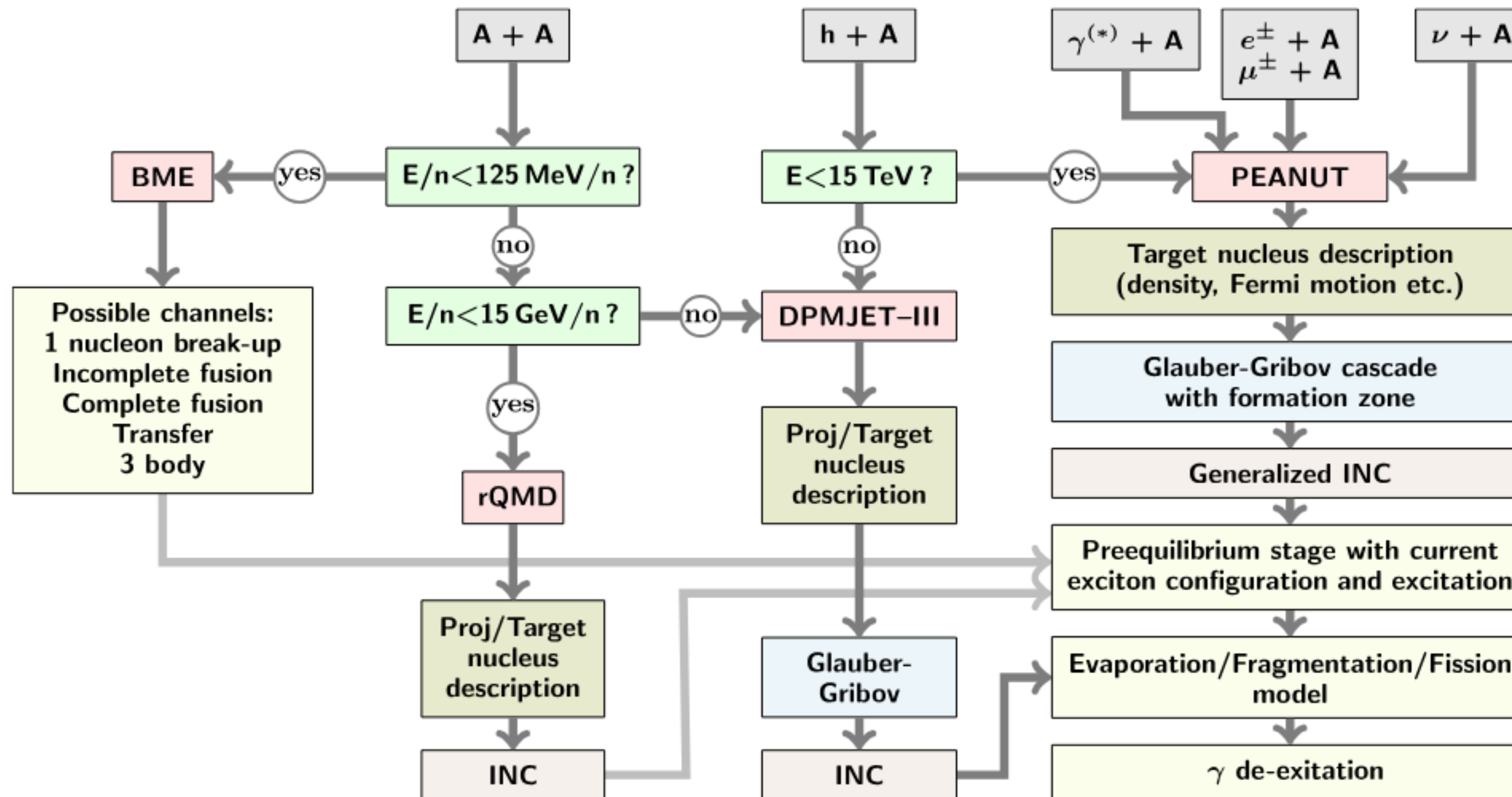

Fig. 1. Inter-relation among the different nuclear interaction models used by FLUKA.